

Reference book

BeoVision Avant – your own Home Theatre

Press just one button on the Beo4 remote control.

The BeoVision Avant video system turns toward you. The curtains slide open, revealing the picture on the screen.

The built-in video tape recorder currently playing your favourite film is placed discreetly inside the chassis. After all, it's what's on the tape that's interesting.

With BeoVision Avant, you have the theatre experience without leaving your living room, much less your home. Add four Bang & Olufsen BeoLab speakers and a BeoLab 2 subwoofer for genuine surround sound.

Contents of the Reference book

To get to know your Bang & Olufsen product, two guides are at your disposal.



To the right, you find the contents of the Reference book. The main chapters of the User's guide are listed below:

- Introducing BeoVision Avant and Beo4, 4
- Watch television, 6
- Turn the TV or adjust sound volume, 7
- Look up Teletext information, 8
- Get access to your favourite Teletext pages, 9
- Load and play a videotape, 10
- Record a programme, 12
- Home Theatre viewing with Avant, 14

Setting up your BeoVision Avant

- 6 Handling your BeoVision Avant
- 6 Placing your TV in your home
- 7 Mounting the base plate
- 7 Overview of displays, close-up operation and connection panels
- 7 Running the cables
- 8 Aerial and mains connections

Loudspeaker connections – surround sound

- 9 Placing loudspeakers
- 10 Connect external speakers
- 11 Set up speaker distance
- 12 Calibrate the sound levels

Connect a set-top box

- 13 AV connection
- 13 IR transmitter

Connect a decoder

- 14 Connect an AV or RF decoder
- 14 Connect two decoders

Connect other equipment

- 15 Extra audio or video equipment

Connect audio and video systems

- 16 Connect your audio system to Avant
- 16 Choose settings

Distribute sound and pictures with BeoLink

- 17 Link systems throughout your home
- 17 The system modulator

Set up BeoVision Avant in a link room

- 18 Before you start...
- 19 Connections
- 19 Link frequency

Register extra equipment

- 20 Equipment connected permanently

Tune in TV or Satellite* channels

- 22 Find available channels

Add new TV or Satellite channels

- 23 Add a new channel

Edit tuned TV or Satellite channels

- 24 Adjust tuned TV channels
- 26 Adjust tuned Satellite channels
- 28 Move tuned channels
- 28 Name tuned channels
- 29 Delete tuned channels

Set the time and date

- 30 Enter settings for the built-in clock

Set positions for viewing and standby

- 31 Preset positions for the TV to turn to

Set your video tape recorder preferences

- 32 Preset recording speed, tape length and track markers

Adjust picture and sound settings

- 34 Change brilliance, colour or contrast
- 35 Change volume, bass, treble or balance

Daily operations

- 36 Select a TV or Satellite channel
- 36 See a channel list
- 37 Adjust viewing position
- 37 Adjust or mute sound volume
- 37 Change sound type or language

Load and play a videotape

- 38 Load a videotape
- 38 Play or stop a tape
- 39 Search through a tape
- 39 Adjust tape tracking, sharpness and 'jitter'

Recording

- 40 Preset a recording from Teletext TV listings
- 41 Preset a Timer recording manually
- 42 See a list of scheduled recordings
- 42 Record here and now
- 43 Copying videotapes
- 43 Record sound alone

Look up Teletext information

- 44 Main Teletext functions
- 45 Store frequently read pages
- 45 Day-to-day use of memory pages
- 45 Activate subtitles from Teletext
- 46 See updated Teletext pages
- 46 Go directly to a page via Fastext

See two sources at the same time

- 47 Picture within a picture

Home Theatre viewing with Avant

- 48 Select speakers for movie sound
- 49 Make the picture fill out the screen

Switch BeoVision Avant on or off automatically

- 50 Timer play and timed standby

Use an integrated audio system

- 52 Use audio or video system speakers

Use BeoVision Avant in a link room

- 53 Use main room and link room sources

The socket panel on the rear

- 54 Overview of sockets

The close-up operation and socket panels

- 56 The close-up operation panel
- 56 The close-up socket panel
- 57 Copy from a CamCorder to Avant
- 57 Connect a set-top box

The BeoVision Avant display bar

- 58 Overview of display elements

Gain access to extra functions via Beo4

- 59 Add to the Beo4 list of functions

Maintenance of your BeoVision Avant

- 60 Day-to-day maintenance

The PIN-code system

- 61 Activate the PIN-code system
- 61 Change or delete your PIN-code
- 62 Use your PIN-code
- 62 Did you forget your PIN-code?

For your information...

- 63 Contact Bang & Olufsen

Key to using this guide

Use this Key to identify what a button, source or status display looks like in an instruction sequence:

TV	<i>Buttons on the Beo4 remote control</i>
	
TV 12	<i>Display on top of BeoVision Avant</i>
SPEAKER	<i>Displays on the Beo4 remote control</i>
FORMAT	

*NOTE! Satellite channels are only available if your BeoVision Avant is equipped with the built-in Satellite receiver module.

Setting up your BeoVision Avant

We recommend that you follow the procedure described below when you set up your BeoVision Avant:

- Unpack the BeoVision Avant and place it as described and illustrated to the right under *Handling your BeoVision Avant*;
- Consider the appropriate surroundings for your Avant. Guidelines are included to the right under *Placing your BeoVision Avant in your home*;
- Mount the base plate as described;
- Connect the cables, additional equipment, and speakers as described on the pages 9–15. For information of how to fasten and run the cables on the rear of BeoVision Avant, refer to the opposite page.

For an overview of the display, close-up operation and socket panels, refer to the opposite page and pages 54–58. The connection panels on the rear of BeoVision Avant are described on the opposite page.

Handling your BeoVision Avant

Due to the weight of the BeoVision Avant, any moving/lifting of the system should always be done by two persons.

The BeoVision Avant has three sets of recesses for lifting the system. The illustrations show the placement of each recess (A, B and C).

Do not attempt to lift the BeoVision Avant holding on to any other parts of the cabinet or rear panel!

Placing your BeoVision Avant in your home

- Avoid placing your BeoVision Avant in direct sunlight or direct artificial light (e.g. a spotlight), as this may reduce the sensitivity of the remote control receiver.
- Make sure that the BeoVision Avant is set up, placed and connected in accordance with this guide.
- The BeoVision Avant is developed for indoor use in dry, domestic environments only, and for use within a temperature range of 10–40° C (50–105° F).
- Do not place any items on top of the BeoVision Avant.
- Do not attempt to open the BeoVision Avant. Leave such operations to qualified service personnel.
- The motorised stand will turn the BeoVision Avant to a preset position when you switch it on. Therefore, when placing BeoVision Avant in your home, leave enough space around the TV to allow it to turn freely.

If the BeoVision Avant (or your videotapes) have been exposed to low temperatures, condensation may occur inside the video tape recorder when the BeoVision Avant is placed in a warm room. In order to avoid damage to the video tape recorder or to the tapes, we recommend that you allow them to acclimatise to normal room temperature before loading.

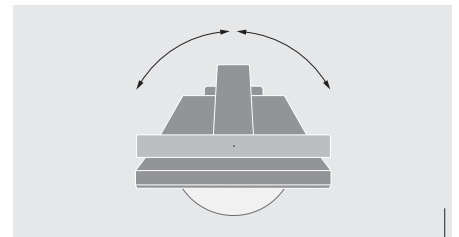
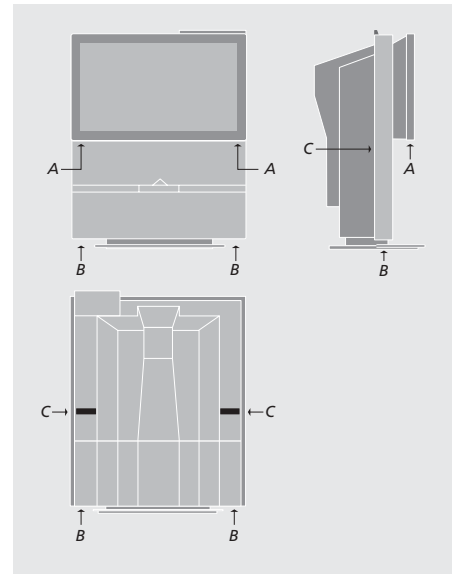

The range of movement for the BeoVision Avant is 70 degrees, or 35 degrees to each side. The television can also be turned by hand.

Mounting the base plate

When you have placed the BeoVision Avant, you must fasten the base plate cover:

- > The cover has been furnished with strips of double-coated tape. Before you fasten the cover permanently, try putting it into place first without removing the tape backing.
- > Lift off the cover again, remove the tape backing, and fasten the cover to the base plate.

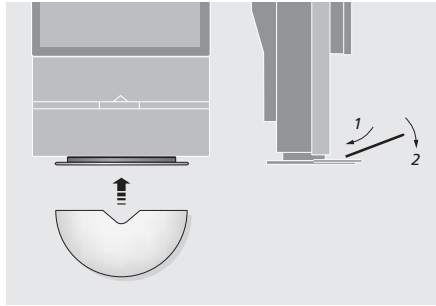

Overview of display, close-up operation and connection panels

The illustrations show the placement of the display, the mains switch and the various socket and connection panels on the BeoVision Avant:

- 1 Avant display bar
- 2 Close-up operation and socket panels
- 3 Mains connection
- 4 Power Link and digital input socket panel*
- 5 AV and aerial socket panel
- 6 V.TAPE DECODER socket panel

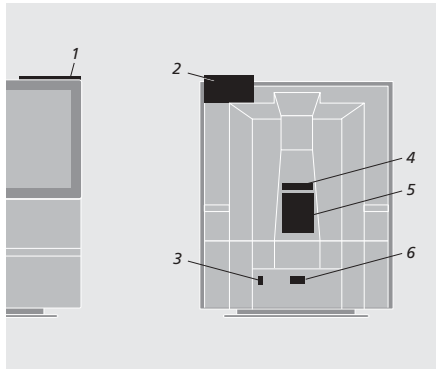

Running the cables

To allow for the movement when the BeoVision Avant turns, it is essential that the cables are run and fastened as depicted:

- > Turn the BeoVision Avant all the way to the left.
- > Run the cables from the AV panel (and the speakers panel) behind the bracket (A) and in a loop to the bracket (B).
- > Fasten all cables neatly to the bracket (B) – using two cable tiers.
- > Run the cable bundle in a broad loop to the small bracket protruding from the base plate, and fasten the cables neatly to it – using two cable tiers (C).
- > Tug the loop of cables neatly into the space provided.

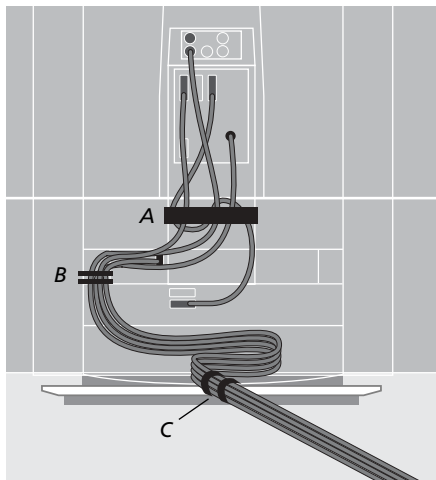

The cables should be handled with care. When running any cable, avoid bending it sharply or twisting it. Avoid subjecting the cables to pressure or impact.

Mains lead

The supplied mains lead and plug are specially designed for the TV. If you change the plug or in any way damage the mains lead, it will affect the TV picture adversely!

*NOTE! These sockets are only available if your BeoVision Avant is equipped with the built-in surround sound module.

When you set BeoVision Avant up on its own, simply connect the aerial and connect the system to the mains.

If you wish to connect any other equipment, please refer to the Connections chapters on pages 9–15 and Register extra equipment on page 20.

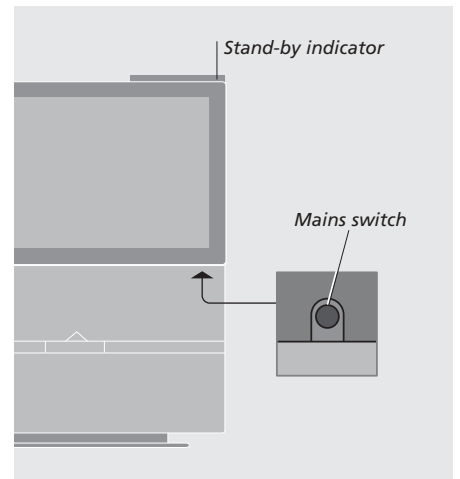
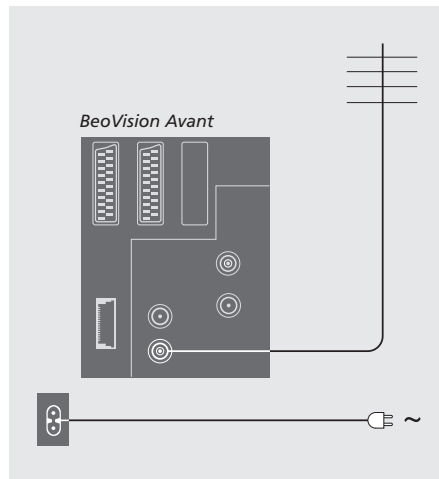

Aerial connection

Using an aerial cable, connect your external aerial (or a cable TV network) to the socket marked VHF/UHF on the BeoVision Avant rear socket panel.

Mains connection

Using the mains cord supplied, connect one end to the socket marked ~ on the rear of the BeoVision Avant, then plug the other end into a wall socket.

Your BeoVision Avant was designed to be left in stand-by mode when not in use. Therefore, to facilitate remote control operation, etc., it is essential that you leave the mains switch on, once you have turned it on.

However, if you are going to connect speakers, an audio system or any other equipment to BeoVision Avant, do not switch on at the mains yet!

When connections are complete...

After you connect and fasten the cables as explained on page 7, you can connect Avant to the mains. Switch on the mains switch on the front of BeoVision Avant. A tiny, red light appears in the display panel. The system is in stand-by mode and ready to be used. If your Avant is set up on its own, you can now start to use it as explained on page 6 in the Guide.

A surround sound setup with the BeoVision Avant is easy to fit into your living room. Determine your ideal listening and viewing position by the picture rather than by the sound. The performance of your speakers is unaltered.

Preset the distances to each speaker from your favourite listening and viewing position, that is, measure the distance to each speaker. The surround sound experience will be noticeable as long as you stay within the area created by the speakers.

In a surround sound* setup, you will have to preset the sound balance between the speakers in your particular setup, that is, perform a speaker balance calibration. Refer to the following pages for further instruction.

Placing loudspeakers

It is important that you find out where you will place your loudspeakers before you start connecting the speakers. Once they are connected, you can make the presets necessary to give you the ultimate sound experience.

The three diagrams to the right indicate examples of BeoVision Avant and loudspeakers placed in various types and sizes of rooms.

The following guidelines apply for all speaker setups:

- The best placement for the rear speakers is on either side behind your favourite listening position.
- The front and rear sets of speakers do not necessarily have to be placed in the corners of the room.
- We recommend that you use your most powerful speakers as your front speakers.
- If you connect a BeoLab 2 subwoofer, refer to the subwoofer's own Guide for information about placement possibilities.

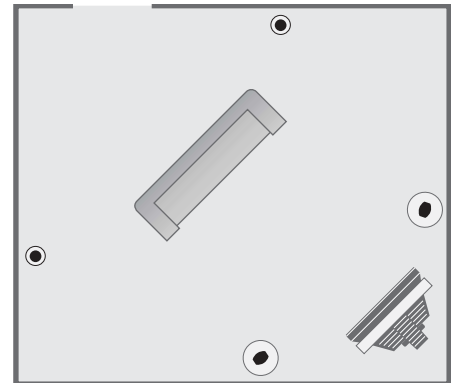
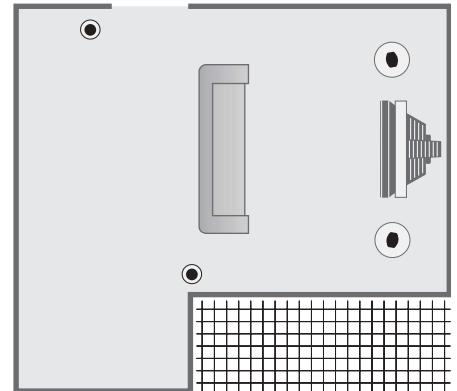
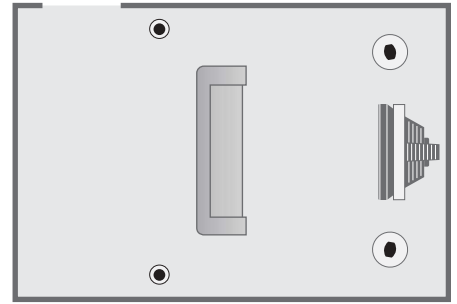

*NOTE! This function is only available if your BeoVision Avant is equipped with the surround sound module.

Connect external speakers

You can connect Bang & Olufsen speakers and a BeoLab 2 subwoofer to BeoVision Avant via the socket panel on the rear of the television. The speakers must be from the range of Bang & Olufsen speakers.

Using the cables enclosed with the speakers, make the following connections:

- > Connect the two external front speakers to the sockets marked FRONT.
- > Connect the two rear speakers to the sockets marked REAR.
- > Connect the subwoofer to the socket marked SUBWOOFER.

You may choose to loop the signals through from speaker to speaker (as described in the guide enclosed with your speakers), or you may connect one speaker to each of the sockets. If necessary, longer cables and adaptors are available from your Bang & Olufsen retailer.

Regardless of what you choose, remember to set the L•R•LINE switch on both the front and rear set of speakers to L or R (left and right channel) to indicate their relative position in each set. Set the left front speaker to L, the right rear speaker to R, and so on.

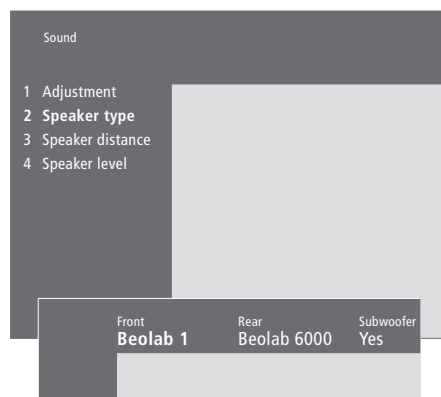
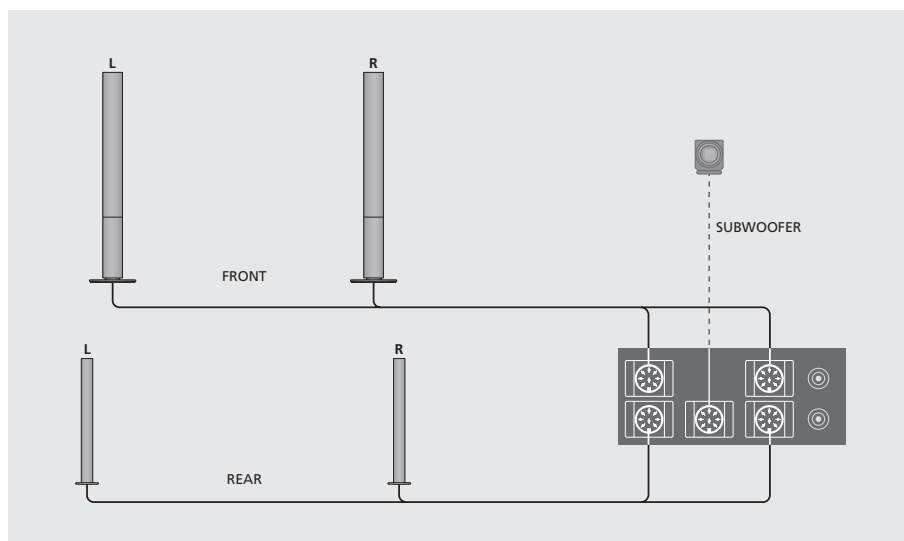

- > Switch on the system and press **MENU** to call up the main menu.
- > Press **4** to call up the Setup menu (5 if Sat is available).
- > Press **2** to call up the *Sound* menu.
- > Press **2** again to call up the *Speaker Type* menu.
- > Press **▼** or **▲** to reveal your speaker type and **▶▶** to move on to the next speaker set. Choose **NONE** if there are no speakers connected.
- > If you have a BeoLab 2 subwoofer, press **▶▶** to move the cursor to Subwoofer and press **▼** to change the field to Yes.
- > Press **GO** to store your choices or **EXIT** to leave the menu.

Options on the *Speaker Type* menu

FRONT

Select the speakers you have connected:
BEOLAB 1, BEOLAB PENTA, BEOLAB 8000,
BEOLAB 6000, BEOLAB 4000, or NONE.

REAR

Select the speakers you have connected:
BEOLAB 1, BEOLAB PENTA, BEOLAB 8000,
BEOLAB 6000, BEOLAB 4000, or NONE.

SUBWOOFER

Indicate whether you have connected a BeoLab 2 subwoofer. Options are YES or NO.

Set speaker distance

Place yourself in your favourite television viewing position and turn on the system. Enter the straight-line distances in meters between your position and the individual speakers.

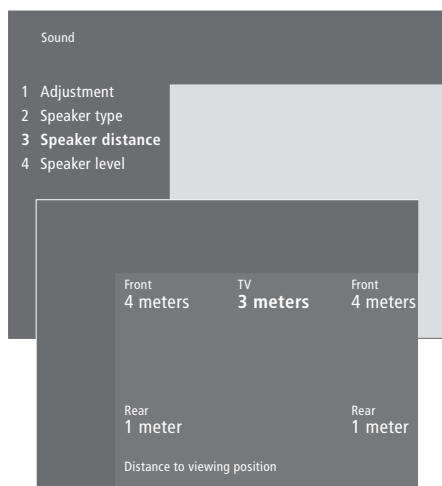

- > Switch on the system and press **MENU** to call up the main menu.
- > Press **4** to call up the *Setup* menu (5 if *Sat* is available).
- > Press **2** to call up the *Sound* menu.
- > Press **3** to call up the *Speaker distance* menu. The connected speakers are shown.
- > Press **◀** or **▶** to move the cursor from speaker to speaker and press **▲** or **▼** to select the approximate straight-line distance in meters between your viewing position and each of the speakers.
- > When you have entered the appropriate speaker distances, press **GO** to store your settings or press **EXIT** to leave the menu.

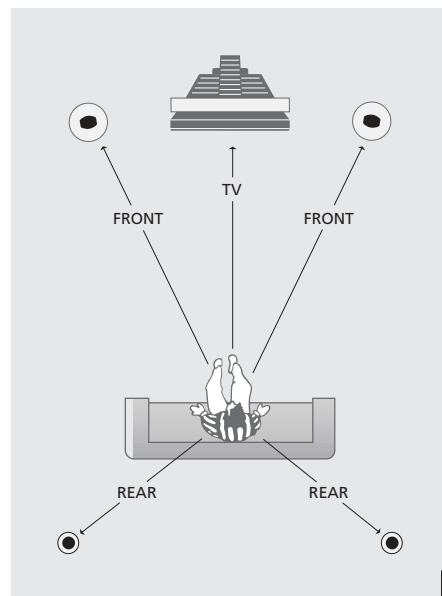

You do not have to enter a distance for a BeoLab 2 subwoofer, as subwoofer placement has little impact on the sound. To adjust subwoofer sound, please refer to page 34, 'Adjust picture and sound settings'.

Calibrate the sound level

When you have connected the necessary speakers in a surround sound setup to the BeoVision Avant, you will have to perform a speaker calibration.

A calibration sound is produced alternately in each of the speakers you have connected in your surround sound setup. Your task is to adjust the sound level from all the connected speakers to match the sound level from Avant's own speakers. You can choose whether you want the sound sequence to occur automatically or manually. Your BeoVision Avant is set for manual sound reproduction, but you can start the automatic sound sequence by pressing MENU on Beo4.

It is not necessary to calibrate subwoofer sound in a surround sound setup. If you still wish to adjust subwoofer sound when your speaker calibration is complete, please refer to 'Adjust picture and sound settings' on page 34.

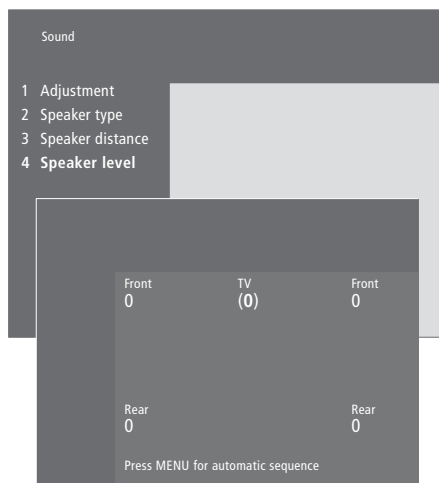

The two sound sequence options

AUTOMATIC

If you select the automatic sequence, the sound shifts automatically between the external speakers every 2–3 seconds. To adjust the speaker levels, you must move the cursor to the speaker to be adjusted first.

MANUAL

If you select the manual sequence, the sound follows the speaker you highlight on the menu. You can then adjust the sound accordingly.

The sound level from the Avant speakers functions as your point of comparison with the external speakers and can not be adjusted here.

- > Switch on the system and press **MENU** to call up the main menu.
- > Press **4** to call up the *Setup* menu (5 if *Sat* is available).
- > Press **2** to call up the *Sound* menu.
- > Press **4** to call up the *Speaker level* menu. *TV* is highlighted and sound is cut in on the Avant speakers.
- > Press **▲** or **▼** to adjust the speaker sound and **◀** or **▶** to move to another speaker.
- > When you have adjusted the sound for all the speakers in your surround sound setup, press **GO** to store your settings or press **EXIT** to leave the menu.

Once you have performed your speaker calibration, you will only need to re-calibrate the speaker sound if you make changes to the setup, e.g. if you move one or more of the speakers.

Connect a set-top box

The connections described on this page refer to a setup where a set-top box is connected to an Avant containing the Set-top Box Controller module.

It is possible to connect the set-top box to either the DECODER or the AV socket on BeoVision Avant.* You can also connect two set-top boxes, one to each socket, but only if your Avant is not equipped with the built-in Satellite receiver module.

You can also connect a second set-top box to Avant via the CamCorder socket. Please refer to *The close-up operation and socket panels* on page 56.

When you have connected your equipment, you must check that the setup is registered in the *Connections* menu. Once the registration has been made, you are requested to select your specific set-top box in the Set-top box menu. Please refer to the chapter *Register extra equipment*, page 20, for further information.

Set-top boxes must be set up in accordance with the documentation enclosed with them.

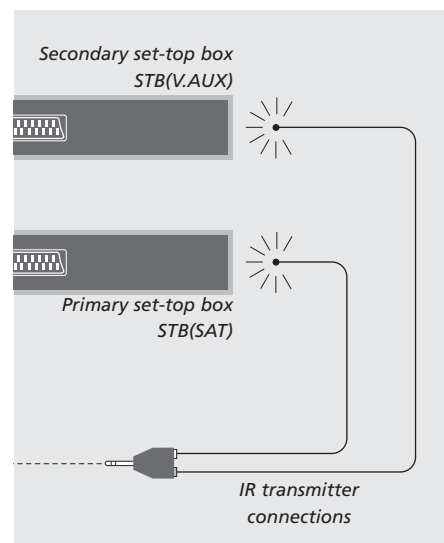
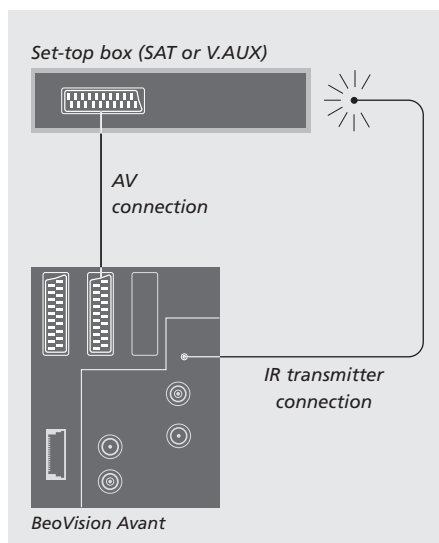

AV connection

Disconnect all involved systems from the mains before you start connecting external equipment. Use the 21-pin AV cable to connect the set-top box to your BeoVision Avant:

- > Connect one end to the set-top box.
- > Run the cable to the AV or DECODER socket on the back of BeoVision Avant.

IR transmitter

In order to enable remote control operation of your set-top box with the Beo4 remote control you must connect the enclosed low power IR transmitter:

- > Connect the IR transmitter to the IR OUTPUT socket on BeoVision Avant.
- > Fasten the IR transmitter to the IR receiver of the set-top box (please follow the instructions enclosed with the IR transmitter).

To be able to use the remote control delivered with your set-top box, do not cover its IR receiver entirely.

If you connect two set-top boxes...

You will need an IR Y-adaptor (index number 6174171) to connect two set-top boxes to your BeoVision Avant. Please contact your Bang & Olufsen retailer. Follow the procedure described below to connect two set-top boxes to BeoVision Avant:

- > Connect your primary and secondary set-top boxes to the AV and DECODER sockets on BeoVision Avant via 21-pin AV cables as shown.
- > Connect the IR Y-adaptor to the IR OUTPUT socket on BeoVision Avant.
- > Connect the IR transmitter for your primary set-top box to the chrome socket on the IR Y-adaptor, and fasten the other end to the IR receiver on your primary set-top box.
- > Connect the IR transmitter for your secondary set-top box to the gold socket on the IR Y-adaptor, and fasten the other end to the IR receiver on your secondary set-top box.
- > Register your primary set-top box in the *Connections* menu as STB(SAT) and your secondary set-top box as STB(V.AUX). Please refer to *Register extra equipment* on page 20 for further instruction.

*NOTE! If you connect a second Bang & Olufsen video tape recorder to your BeoVision Avant, you must connect your set-top box to the DECODER socket on the BeoVision Avant.

Connect a decoder

The connections described on this page assume a setup with an AV decoder (a baseband decoder, e.g. Canal+, or a MAC decoder, etc.) and BeoVision Avant.

It is possible to connect a decoder to both the DECODER and AV socket on BeoVision Avant*. If your setup includes a BeoCord V 8000 video tape recorder, then you should connect the primary decoder to BeoCord V 8000.

Whatever setup you choose, you must check that the setup is registered in the *Connections menu*.

Please refer to the chapters, *Register extra equipment* on page 20 or *Socket panel on the rear* on page 54, if you require further information or instruction regarding externally connected equipment.

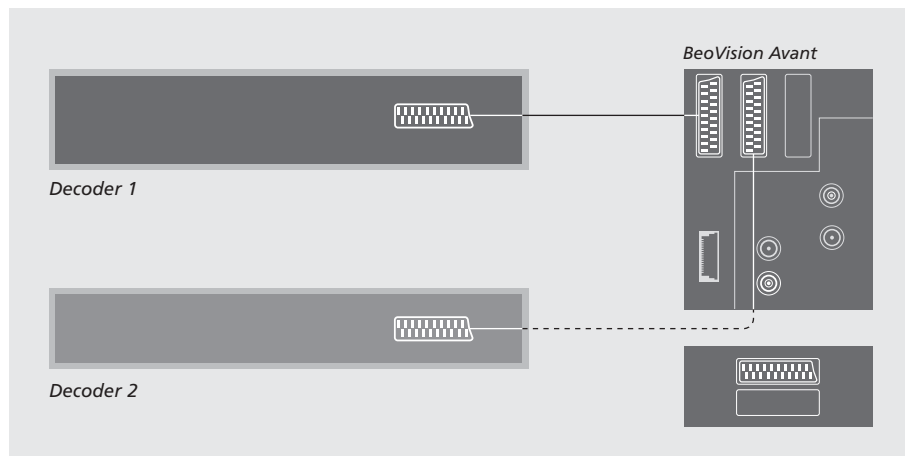

Connect an AV or RF decoder

To connect an AV decoder (a baseband decoder, e.g. Canal+, or a MAC decoder, etc.), connect the cable from the aerial to the BeoVision Avant as usual. Connect the AV decoder to the 21-pin socket marked DECODER on the BeoVision Avant.

If you wish to connect an RF decoder, then remember to connect the external aerial cable to the decoder input socket and then forward the signal or cable to the BeoVision Avant aerial socket (marked VHF/UHF). Connect the RF decoder to the 21-pin socket marked DECODER on the BeoVision Avant.

If your decoder has two 21-pin sockets, it is important that you use the socket intended for a video tape recorder and not the socket which may be marked TV!

If you wish to record a coded programme on BeoVision Avant's built-in video tape recorder, you can connect your decoder to the V.TAPE DECODER socket. Please refer to *The socket panel on the rear* on page 54 for more information.

Connect two decoders

If you connect two decoders to BeoVision Avant, connect your primary decoder to the DECODER socket and your secondary decoder to the AV socket on BeoVision Avant

**The decoder you connect to the AV socket in this case can not be a MAC or baseband decoder!*

You can connect different types of audio or video equipment to BeoVision Avant, such as a DVD player, satellite dish or CamCorder.

When connecting other equipment to your BeoVision Avant, remember to use the AV socket on BeoVision Avant first, if it is vacant.

Please refer to the User's Guide included with your equipment to make sure it is connected properly.

Remember to register all connected equipment as well. Refer to page 20, *Register extra equipment*, for more information.

Satellite dish

The connection of a satellite dish to the BeoVision Avant requires a built-in Satellite receiver module. Likewise, if you want to connect a polarotor, etc., your BeoVision Avant must have an external positioner box. Please contact your Bang & Olufsen retailer.

For specific information on how to set up and use your Satellite system, please refer to the guide enclosed with the Satellite module (BeoSat Avant – dish and decoder setup) and to the BeoVision Avant User's guide.

AV 2 Expander

The optional AV 2 Expander accessory enables you to connect more than one piece of auxiliary equipment to one socket on BeoVision Avant. You can connect a decoder, a compact video disc player, and other auxiliary equipment to Avant via the AV 2 Expander.

Use a 21-pin cable to connect one plug to the socket marked TV on the Expander box, and connect the other plug to the socket marked DECODER on BeoVision Avant.

Second video recorder

Use a 21-pin cable to connect the video recorder to the AV socket on BeoVision Avant. Connect the cable from the aerial to the input socket on the second video recorder. Forward the aerial signal to the aerial socket on BeoVision Avant.

DVD player

Use a 21-pin cable to connect a DVD player, such as a Bang & Olufsen DVD 1, to BeoVision Avant. Connect one end to the socket marked AV on your DVD player, and the other to the socket marked AV on BeoVision Avant.

Video game, CamCorder, etc.

We recommend that you use the close-up sockets for types of equipment not usually connected permanently. These sockets are placed directly below the close-up operation panel. The use of close-up sockets is explained on page 56, *The close-up operation and socket panels*.

Connect your audio and video systems

If you connect a compatible Bang & Olufsen audio system to the BeoVision Avant using a BeoLink cable, you will obtain the benefits of an integrated audio/video system.

Play a CD on your audio system using the speakers in your BeoVision Avant, or turn on a TV programme and send the sound to your audio system speakers.

Your AV system can be placed together in one room, or in two rooms with the BeoVision Avant (with or without external speakers) placed in one room, and the audio system with a set of speakers placed in another.

Connect your audio system to Avant

Using a BeoLink cable, connect the one multi-pin plug to the socket marked MASTER LINK on BeoVision Avant, and the other multi-pin plug to the socket marked MASTER LINK on the audio system. Please refer to *The socket panel on the rear* on page 54 for more information.

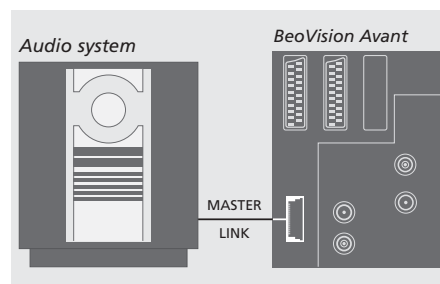

Choose settings

If your BeoVision Avant has been set up in an AV system, you may need to program it to the correct Option. Option programming is done with the Beo4 remote control and with the entire system switched to stand-by.

Option programming for BeoVision Avant:

- > Hold the **•** button while pressing LIST.
- > Let go of both buttons.
- > Press LIST until the Beo4 display reads OPTION? and then press GO.
- > Press LIST to display V.OPT and then key in the appropriate number (0, 1 or 2).

Option programming for the audio system:

- > Hold the **•** button while pressing LIST.
- > Let go of both buttons.
- > Press LIST until the Beo4 display reads OPTION? and then press GO.
- > Press LIST to display A.OPT and then key in the appropriate number (0, 1, or 2).

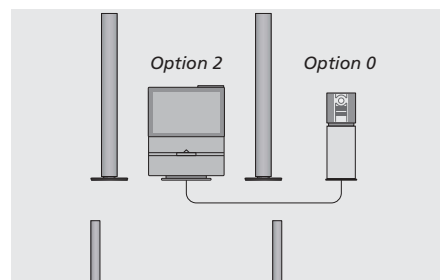

BeoVision Avant and an audio system set up in one room – all speakers are connected to the BeoVision Avant.

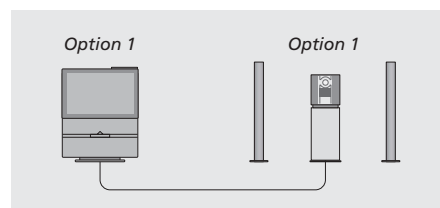

You can choose to set up your BeoVision Avant (with or without connected speakers) and the audio system (with a connected set of speakers) in the same room.

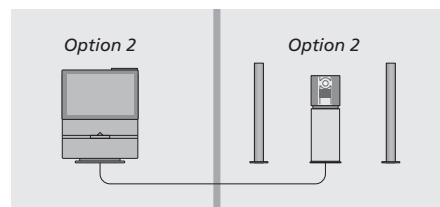

You can choose to set up your audio system in one room, and the BeoVision Avant (with or without connected speakers) in another.

The BeoLink system makes it possible to distribute picture and/or sound to other rooms throughout the house.

You can connect your BeoVision Avant in e.g. the living room to another video system or set of speakers in another room, thereby making it possible to 'move' the picture or sound to other rooms.

Link systems throughout your home

The link room system must be connected via a BeoLink cable to the system in the main room:

- > Connect the BeoLink cable to the socket marked MASTER LINK on BeoVision Avant.
- > If you want to distribute video signals as well, connect an ordinary aerial cable to the socket marked LINK on BeoVision Avant. Then run both cables to the link room and follow the instructions enclosed with the link room equipment.
- > If the Master Link socket on the BeoVision Avant already has an audio system connected, you have to split the Master Link cable in two and join them with the cable from the link room using a special junction box. Please consult your Bang & Olufsen retailer.

The system modulator

The system modulator ensures that the systems in the main and link rooms can communicate back and forth. Under special circumstances, it may be necessary to enter modulator settings:

- If your link room is an audio setup, e.g. a BeoLink Active/Passive, and you choose to set up a non-linkable TV as well, you must set the system modulator to *On*, as described to the right (the factory setup is *Off*, which must be used if you are using a linkable Bang & Olufsen TV).
- If, for example, a TV station in your area is broadcasting at the same signal frequency the BeoLink system uses, 599 MHz, you must tune the system modulator to an unoccupied frequency, as described on page 19.

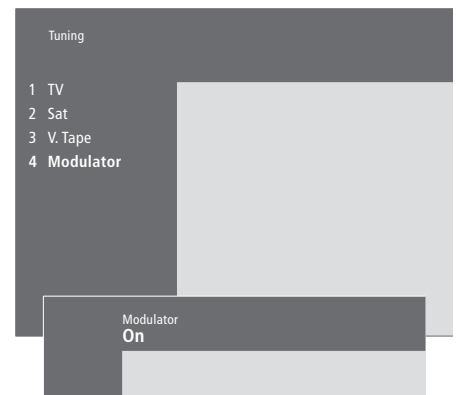
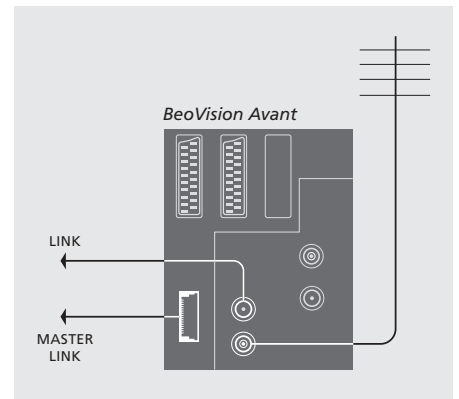

To switch on the Avant system modulator*:

- > Switch on the system and press **MENU** to call up the main menu.
- > Press **4** to call up the *Setup* menu (5 if *Sat* is available). *Tuning* is already highlighted.
- > Press **GO** to call up the *Tuning* menu.
- > Press **▼** to move the cursor down to the *Link frequency* menu.
- > Press **MENU** to reveal the item *Modulator*.
- > Press **GO** to call up the Modulator menu.
- > Press **▲** or **▼** to change from *Off* to *On* or vice versa.
- > Press **GO** to store the setting or **EXIT** to leave all menus.

*NOTE! This setting can only be adjusted if your BeoVision Avant is equipped with the system modulator.

Set up BeoVision Avant in a link room

If you have a BeoLink distribution system installed, you can either use your BeoVision Avant in the main room, such as a living room, or in a link room, such as a study or bedroom.

If you choose to use your BeoVision Avant in a link room, you can sit in the link room and enjoy all of Avant's features, as well as audio or video from the main room.

You can, for example, listen to radio programmes from a main room audio system, watch a DVD film from a DVD player connected in the main room, or watch a videotape played on a main room video tape recorder while your Avant in the link room records another programme at the same time.

This chapter describes how to set up your BeoVision Avant for use in a link room.

Before you start...

If you choose to use your BeoVision Avant in a link room, there are some changes in the way you would otherwise set it up. These changes are outlined below. You must follow this procedure when connecting your BeoVision Avant for use in a link room:

- 1 Connect the system to the mains;
- 2 Using the Beo4 remote control, program the link room BeoVision Avant to Option 6*;
- 3 Disconnect BeoVision Avant from the mains;
- 4 Make the connections described on these pages;
- 5 Reconnect BeoVision Avant to the mains.

Program BeoVision Avant for link room use

- > Connect BeoVision Avant to the mains and switch the power on as described on page 8.
- > Hold the **•** button down on Beo4 while pressing **LIST**.
- > Release both buttons.
- > Press **LIST** repeatedly until **OPTION?** is shown in the Beo4 display and press **GO**.
- > Press **LIST** repeatedly until **V.OPT** is shown in the Beo4 display and press **5** or **6**.

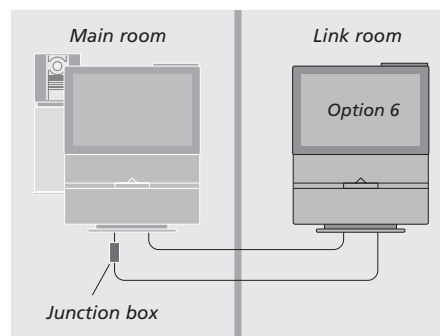

For your entire system to function properly, it is essential that the BeoVision Avant in the link room is programmed to either 'Option 5' or 'Option 6' before you connect it to the system in the main room!

**If you connect Avant for use in a link room where other link systems are already connected, such as loudspeakers, then you must program Avant to Option 5 instead.*

Connections

Your BeoVision Avant in the link room must be connected to your main room system using two different cables:

- BeoLink connection (using a Master Link cable and a junction box).
- Aerial connection (using ordinary aerial cable).

BeoLink connection

In the main room: Connect the Master Link cable to the socket marked MASTER LINK on the main system. Run the cable to the junction box, and cut the cable to an appropriate length.

In the link room: Connect the Master Link cable to the socket marked MASTER LINK on the BeoVision Avant. Run the cable to the junction box, and cut the cable to an appropriate length.

Inside the junction box: Join the cables as explained in the folder enclosed with the box/cable. This folder explains all the possibilities for the box, and how to join the cables.

Aerial connection

Using an ordinary TV aerial cable (coaxial cable), connect one end to the socket marked LINK on the main system, and the other end to the aerial input socket on the link room TV.

Link frequency

If a TV station is broadcasting on the same frequency that the main room system uses to send video to the link room (set at the factory to 599 MHz), you may need to adjust the main room system's video transmission frequency.

When the connections are complete, you can begin tuning in the TV stations in your area, presetting the sound and picture levels, etc., as described on the following pages.

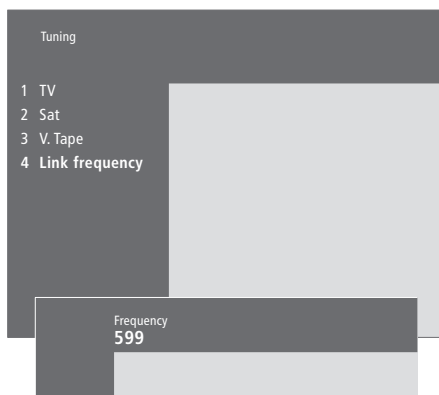

- > Press **MENU** to call up the main menu.
- > Press **4** to call up the Setup menu (5 if *Sat* is available).
- > Press **GO** to call up the *Tuning* menu.
- > Press **3** to call up the *Link frequency* menu (4 if *Sat* is available).
- > Press **▲** or **▼** to find an unused frequency. Alternatively, key in the frequency, e.g. 599, using the number keys on Beo4.
- > Press **GO** to store your setting, or **EXIT** to leave all menus.

Register extra equipment

If you connect additional video sources or equipment to your BeoVision Avant, then you must register the equipment in the *Connections* menu.

The *Connections* menu tells the system what is connected to the sockets on the rear of BeoVision Avant.

For information about where and how to connect extra equipment, please refer to the *Connections* chapters on pages 9–15 as well as *Socket panel on the rear* on page 54.

Registering the equipment connected to BeoVision Avant enables you to operate it via the Beo4 remote control.



- > Switch on the system and press **MENU** to call up the main menu.
- > Press **4** to call up the *Setup* menu (5 if *Sat* is available).
- > Press **5** to call up the *Connections* menu.
- > The two main sockets for extra equipment, *AV* and *Decoder*, are shown, as well as the default settings for those sockets, *DVD* and *Decoder*.
- > Press **▶▶** to select a socket.
- > Press **▲** or **▼** to step through the list of available equipment types until you find what you have connected. Select **NONE** if nothing is connected.
- > When you have selected your equipment types, press **GO** to store your settings or press **EXIT** to leave all menus.

A single source type, such as a video tape recorder, can not be registered twice in the 'Connections' menu, with the exceptions of two decoders or two set-top boxes. See pages 13–14 for further information.

Equipment you can connect to each socket

AV

Non B&O V.TP2

for a non-Bang & Olufsen video tape recorder.

V.Tape2

for a second Bang & Olufsen video tape recorder.

S-VHS V.TP2

for a Super-VHS video tape recorder.

DVD

for a DVD player.

Decoder(2)

for a second decoder. Attach your primary decoder to the DECODER socket.

Doorcam

for a door camera. This option is only available if your BeoVision Avant is equipped with a built-in Picture-in-picture module.

STB(SAT), STB(V.AUX)

for a set-top box. Choose STB(SAT) if you have a secondary set-top box connected to the DECODER socket.

V.AUX

for other extra equipment.

NONE

if no extra equipment is connected.

DECODER

Non B&O V.TP2

for a non-Bang & Olufsen video tape recorder.

DVD

for a DVD player.

Decoder(1)

for your primary decoder.

STB(SAT), STB(V.AUX)

for a set-top box. Choose STB(V.AUX) if you have a primary set-top box connected to the AV socket.

V.AUX

for other extra equipment.

NONE

if no extra equipment is connected.

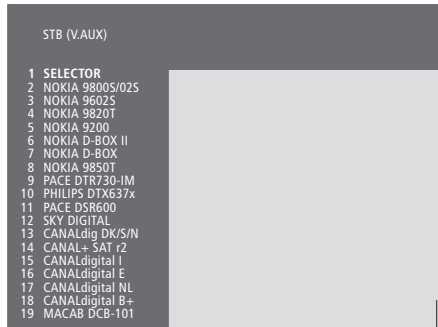

If you select STB in the 'Connections' menu, you will be prompted to choose your STB type from a list on the screen.

If you have connected a set-top-box...

The set-top box options only appear if your BeoVision Avant is equipped with the built-in Set-top Box Controller module. Two set-top boxes can only be connected to Avant if your Avant does not have the built-in Satellite receiver module. If your AV socket is in use, you can connect a second set-top box to the CamCorder socket.

Please refer to *The close-up operation and socket panels* on page 56 for more information.

> Press **▼** to move down the list.

> Press **GO** to select your STB type.

Get access to extra equipment

> To switch on a connected video tape recorder, press **LIST** on your Beo4 remote control until V.TAPE2 is shown, then press **GO**.

> To switch on a connected DVD player, press the **DVD** button on Beo4.

> To use your door camera, switch your BeoVision Avant on when you hear the door bell. If your TV is on when the bell rings, the door camera picture may appear automatically. To remove the door camera picture, press **TV** or another source button on Beo4.

> If you wish to gain access to your set-top box functions and your BeoVision Avant is not equipped with the built-in Satellite receiver module, press the **SAT** button on Beo4. Otherwise, press **LIST** on Beo4 until V.AUX is shown in the display, and then press **GO**.
> For all other auxiliary equipment, press **LIST** on Beo4 until V.AUX is shown in the display, and then press **GO**. This equipment can not be used if your set-top box is registered as STB(V.AUX).

In order to display V.AUX or V.TAPE2 on Beo4, these options must be added to the Beo4 list of functions. See page 59, 'Gain access to extra functions via Beo4', for more information.

Tune in TV or Satellite channels

You can make BeoVision Avant find your TV and Satellite* stations for you, or you can key in the station's exact frequency yourself.

You can preset 99 different TV stations and 119 different Satellite channels on channel numbers of their own, as well as give each station a distinct name.

Find available channels

When you set up Avant for the first time, you can tune in those TV and Satellite channels available in your area via the *TV tuning* and *Sat tuning* menus. BeoVision Avant finds channel signals and stores them by number and name.

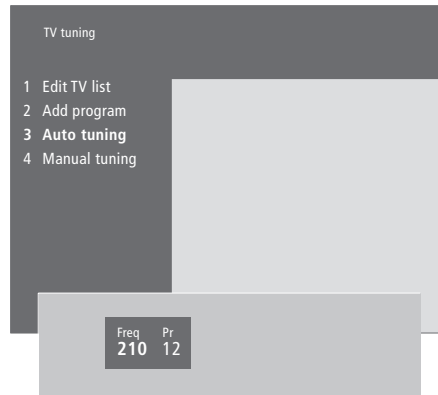

- > Switch on the system and press **MENU** to call up the main menu.
 - > Press **4** to call up the *Setup* menu (5 if *Sat* is available).
 - > Press **GO** to call up the *Tuning* menu.
- If your BeoVision Avant is not equipped with the built-in satellite receiver module or the system modulator, the TV tuning menu will appear automatically. Otherwise...*
- > ...press **GO** again to call up the *TV tuning* menu, or press **2** to call up the *Sat tuning* menu.
 - > Press **3** to call up the *Auto tuning* menu. The *Freq* (frequency) and *Pr* (program) fields are shown.
 - > Press **▲** to start automatic tuning. The content of the frequency and program fields will show your progress.

*When tuning is completed, you can rearrange, delete or rename channels from a channel list. This list also appears if you press **STOP** during auto tuning. Refer to 'Edit tuned TV or Satellite channels' on pages 24–29 for information about editing the channel list.*

*NOTE! It is only possible to tune in Satellite channels if your BeoVision Avant is equipped with the built-in Satellite receiver module.

With BeoVision Avant, you can tune in new channels or re-tune channels previously deleted.

During this tuning process, your previously tuned channels are left alone. This allows you to keep channel names, their order in the channel list, and any special settings that you have stored for those channels, such as decoder or broadcast system settings.

Add a new channel

You can add new or previously deleted TV and Satellite channels to your channel lists at any time via the Add program menu.

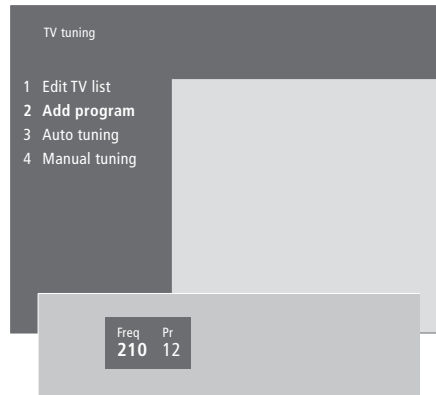

- > Switch on the system and press **MENU** to call up the main menu.
- > Press **4** to call up the *Setup* menu (5 if *Sat* is available).
- > Press **GO** to call up the *Tuning* menu.
- > Press **GO** again to call up the *TV tuning* menu. To add Satellite channels, press **2** to call up the *Sat* menu.
- > Press **2** to call up the *Add program* menu.
- > Press **▲** to begin adding new channels. The *Freq* (frequency) and *Pr* (program) fields will show tuning progress.
- > Press **STOP** to stop adding channels. You can then move, rename or delete channels from a list, as described on pages 28–29.
- > Press **EXIT** when your channels have been tuned in, named and put in the order you choose.

Edit tuned TV or Satellite channels

You can make adjustments to your tuned TV and Satellite* channels at any time.

You can tune in channels not stored during auto tuning by entering the channel frequency and channel number.

You can also enter settings before you tune in channels. These may include choosing a broadcast system for certain types of channels, or setting up a connected decoder to be switched on automatically whenever a coded channel is switched on.

In addition, you can edit your list of channels by renaming channels, moving them around in the list, or deleting them.

Finally, you can make adjustments to the individual channels by choosing a suitable picture format or sound type.

Adjust tuned TV channels

If you wish to watch your programmes in a specific picture format or program a channel for a particular sound type, then call up the **Manual tuning** menu.



- > Switch on the system and press **MENU** to call up the main menu.
- > Press **4** to call up the *Setup* menu (5 if *Sat* is available).
- > Press **GO** to call up the *Tuning* menu.
- > Press **GO** again to call up the *TV tuning* menu.
- > Press **4** to call up the *Manual tuning* menu.
- > Press **◀** or **▶** to move between items on the menu and **▲** or **▼** to view your choices for each item. Numeric values can be entered using the number keys on Beo4.

If the item 'System' appears on the menu, then make sure that the correct broadcast system is displayed before you begin tuning.

- > To view more options, press **▶** to move the cursor to *More* and press **GO**.
- > Press **GO** when you have entered your settings, or press **EXIT** to leave all menus.

*NOTE! Satellite channels are only available if your BeoVision Avant is equipped with the built-in Satellite receiver module.

What's on the first TV manual tuning menu...

Freq (frequency)

Searching stops at the first channel producing an acceptable signal. If you know a channel's exact frequency number, key it in directly using the number keys on Beo4.

(System)

If *System* appears on the menu, make sure that the correct broadcast system is displayed before you start tuning:

B/G... for PAL/SECAM B/G

I... for PAL I

L... for SECAM L

M... for NTSC

D/K... for PAL/SECAM D/K

All options may not be available, as this depends on the television type.

Pr (program number)

Key in the program number (1-99) you wish to preset the channel on.

Name

The name you give a channel will appear in the TV channel list. A name may contain up to eight characters, including the letters A-Z, numbers and full stop. Press ▲ or ▼ to reveal the character you want. Then press ► to move on to the next character position. Please refer to page 28, *Name tuned channels*, for more information.

More

If it is necessary to fill in extra information, move to *More* and press GO. A second manual tuning menu appears.

What's on the second TV manual tuning menu

Fine (fine tuning)

The TV automatically tunes to the best possible picture. However, neighbouring channels may blur the picture slightly, in which case fine tuning may be required. The fine tuning range is ± 8 .

Decoder

If you have only one decoder connected, your options are *ON* or *OFF*. If you have two decoders connected to BeoVision Avant, you can choose between *Dec1*, *Dec2*, or *OFF*.

Sound (mono/stereo/language)

Several types of sound may be available for a TV channel, for example both stereo and mono sound, or several different languages. Press ▲ or ▼ to switch between the sound modes currently transmitted, when the sound you wish to store is heard/displayed, press GO.

Even though you store a type of sound/language in this way, you can switch between the various types while you are watching this TV channel.

Refer to page 37, 'Change sound type or language', for more information about the various types of sound available.

Format

Two format settings are available. You can store a format for each TV channel. The default setting is 15:9, but if 'noise' appears to the right and left of the picture, choose the 14:9 format instead, enabling the curtains on the TV screen to hide the 'noise'.

Even though you store a type of picture format in this way, you can switch between the various types while you are watching this TV channel.

Refer to page 49, 'Make the picture fill out the screen' for more information.

Adjust tuned Satellite channels

You can store Satellite channels on their own channel numbers, fine tune the channel reception, indicate the presence of coded channels and choose appropriate sound types for the individual channels.

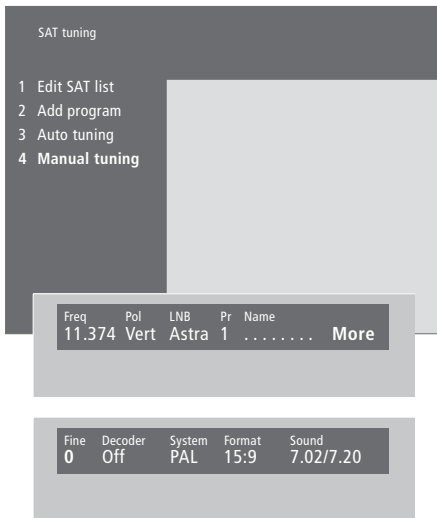

- > Switch on the system and press **MENU** to call up the main menu.
- > Press **5** to call up the *Setup* menu.
- > Press **GO** to call up the *Tuning* menu.
- > Press **2** to call up the *Sat tuning* menu.
- > Press **4** to call up the *Manual tuning* menu.
- > Press **◀** or **▶** to move between items on the menu and **▲** or **▼** to view your choices for each item. Numeric values can be entered using the number keys on Beo4.
- > To view more options, press **▶▶** to move the cursor to *More* and press **GO**.
- > Press **GO** when you have entered your settings, or press **EXIT** to leave all menus.

What's on the first *Sat manual tuning* menu

Freq (frequency)

Searching stops at the first acceptable signal. If this is not a channel you want, press **▲** or **▼** again to continue searching, or key in the exact frequency number.

Pol (polarity)

Pol can be set to *Vert* (vertical polarisation), *Hor* (horizontal polarisation), or *00* – *63* (numerical indication of polarisation). The last is relevant only if polarity is set to *Skew* in the ODU (Out Door Unit) setup menu. Refer to the ODU Setting-up guide for further information about the ODU setup menu.

(Pos (dish position))

Only available if your ODU setup also includes a motor-controlled dish.

(LNB (Low Noise Block Converter))

Only available if you have registered more than one LNB in the ODU setup menu. Options are: *Astra*, *1°West*, *5°East*, *Hot Bird*, *Uni-LNB*, *Telecom*, *SMATV*, *Custom*, and *None*. The LNB options you choose will appear in the first *Sat manual tuning* menu.

Pr (program number)

The numbers 1–119 are available.

Name (channel naming)

You can give a channel a name containing up to eight characters, including A–Z, numbers and full stop. Press **▲** or **▼** to reveal a character. Press **▶▶** to move to the next character position. If you have tuned in a Satellite radio station, you can indicate this in the name (e.g. R for radio) to distinguish between Satellite radio stations and TV channels.

More

Press **GO** to call up the second *Sat manual tuning* menu.

The second Sat manual tuning menu...

Fine (fine tuning)

Fine tune within a range of -7 and +7 to find the best possible picture quality.

Decoder

If you have only one decoder connected, your options are *ON* or *OFF*. If you have two decoders connected to BeoVision Avant, you can choose between *Dec1*, *Dec2*, or *OFF*.

System (Satellite broadcast system)

You can switch between the following systems, *PAL*, *MAC* or *BB* (BaseBand). If you set *System* up to the *MAC* or *BB* options, it will not be possible to select or set options for *Sound*.

Format

Two settings are available. You can store a format for each Satellite channel. The default setting is 15:9, but if 'noise' appears in the right and left side of the picture, choose the 14:9 format instead. The curtains on the TV screen will hide the 'noise'.

You can still change the picture format for each program even though you have stored a setting. Refer to page 49, 'Make the picture fill out the screen', for more information.

Sound (mono/stereo/language)

Several types of sound may be available for a particular satellite station, e.g. both stereo and mono sound, or several different languages.

Press **▲** or **▼** to switch between the options currently transmitted, and stop when the sound you wish to store is heard and/or displayed.

Alternatively, you may have to call up a sound tuning menu to tune in the appropriate sound frequency. Call up the *Sound tuning* menu by pressing **MENU** when *Sound* is highlighted.

You can still switch between the different types of sound/language while you are watching or listening to a Satellite programme, even though you have stored a setting. See page 37, 'Change sound type or language' for more information about the various types of sound available.

What's on the Sound menu...

Sound

Stereo and Mono sound are available.

(Freq (Frequency))

Only applies for when Mono sound is selected.

Tune in the mono sound frequency.

(Left – Right)

Only applies if Stereo sound is selected. Press **▼** or **▲** to select a frequency for the left channel, and the right channel will be adjusted automatically.

(Bandwidth)

Only applies if Mono sound is selected. The following options are available: *130 KHz*, *280 KHz*, and *450 KHz*. Use **▲** or **▼** to reveal options. If *Sound* is set to *Stereo*, the bandwidth is set to *130 KHz* automatically.

Deemphasis

De-emphasise the sound signal, so that it corresponds to the degree of emphasis with which it was transmitted. Options are *50*, *75*, or *J17*.

Expand

Expand the sound signal. Applies if the transmitted sound is a stereo signal. Expand compensates for the deviations bass and treble undergo during transmission. Options are *On* and *Off*.

Sound level

Select a sound level for a station. As some stations broadcast programmes with different sound levels, you can e.g. choose to turn the preprogrammed sound level down. Options are *Normal* and *Low*.

Picture

Indicates whether your station is a Satellite Radio or TV station. *On* indicates that the picture screen will be switched on for Satellite TV stations, and *Off* indicates that the picture screen will not be switched on, as only radio sound is available.

Move tuned channels

You can rearrange the order in which your channels appear when you switch channels, as well as in the on-screen channel list.

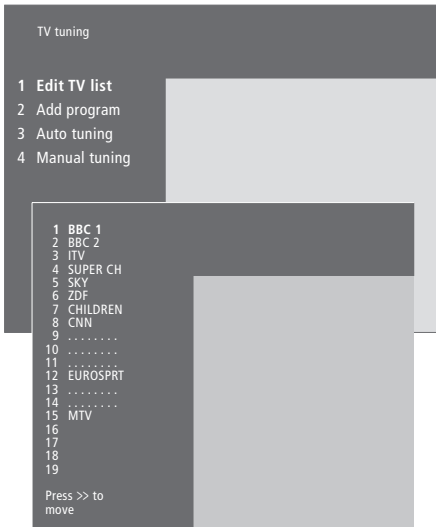

- > Switch on the system and press **MENU** to call up the main menu.
- > Press **4** to call up the *Setup* menu (5 if *Sat* is available).
- > Press **GO** to call up the *Tuning* menu.
- > Press **GO** again to call up the *TV tuning* menu. To move Satellite channels, press **2** to call up the *Sat tuning* menu.
- > Press **GO** to call up the channel list.
- > Press **▼** or **▲** to move through your list of channels.
- > When you find a channel you wish to move, press **▶▶** to move it out of the list. *You can select a channel while another channel is out of the list, but be sure to move the channel back into the list before exiting the menu.*
- > Press **▼** or **▲** to move the channel to its new location, or press the number of the new location.
- > Press **◀◀** to move the channel back into the list. If it changes places with another channel, this channel is moved out of the list and can be placed elsewhere.
- > When you have moved your channels, press **EXIT** to leave all menus.

Name tuned channels

BeoVision Avant will name your tuned channels automatically during auto tuning, but you can rename your channels at any time, thereby making it easier to locate them.

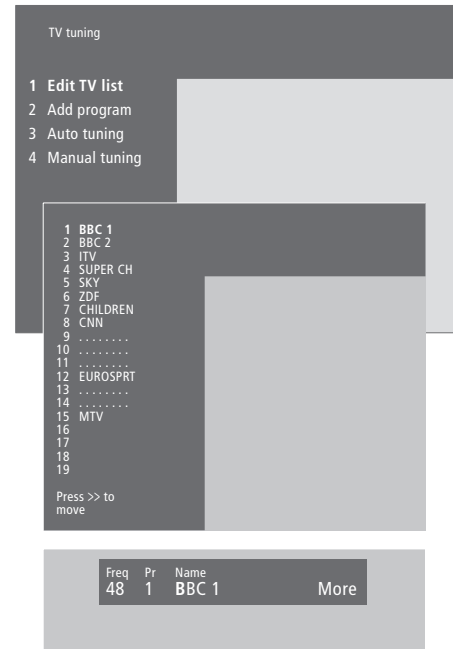

Delete tuned channels

You can remove all your unwanted tuned channels from the channel list, thereby reducing the time you spend changing channels.

- > Switch on the system and press **MENU** to call up the main menu.
- > Press **4** to call up the *Setup* menu (5 if *Sat* is available).
- > Press **GO** to call up the *Tuning* menu.
- > Press **GO** a second time to call up the *TV tuning* menu. To name Satellite channels, press **2** to call up the *Sat tuning* menu.
- > Press **GO** to call up the channel list.
- > Press **▼** or **▲** to move through your list of channels.
- > When you have found a channel you wish to name, press **GO**. The cursor will be located on the first character in the channel name.
- > Press **◀** or **▶** to move between characters.
- > Press **GO** to store a name and return to the list, or press **STOP** to return to the list without storing the name.
- > Press **EXIT** to leave all menus.

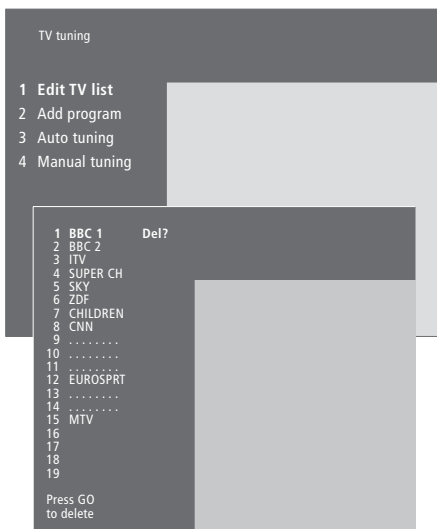

- > Switch on the system and press **MENU** to call up the main menu.
- > Press **4** to call up the *Setup* menu (5 if *Sat* is available).
- > Press **GO** to call up the *Tuning* menu.
- > Press **GO** again to call up the *TV tuning* menu. To delete Satellite channels, press **2** to call up the *Sat tuning* menu.
- > Press **GO** to call up the TV channel list.
- > Press **▼** or **▲** to move through your list of channels.
- > When you have found a channel you wish to delete, press **MENU**. *Del?* appears next to the channel name.
- > Press **GO** to delete the channel, or press **STOP** to return to the list without deleting the channel.
- > Press **EXIT** to leave all menus.

Set the time and date

BeoVision Avant is equipped with a built-in 24-hour clock that can display the time while Avant is on, or display it on request.

When you preset BeoVision Avant to switch itself on or off at a particular time, or when you preset a Timer recording of a programme, the clock ensures that these features are switched on and off at the right times.

The simplest way to set the clock is to synchronise it with a tuned channel's Teletext service via BeoVision Avant's Clock menu. It is only possible to synchronise the clock with the Teletext service offered by the current TV channel. If a Teletext service is not available, you can set the clock manually.

Enter settings for the built-in clock

Before synchronising the clock with a tuned channel, make sure that the channel in question offers a Teletext service.

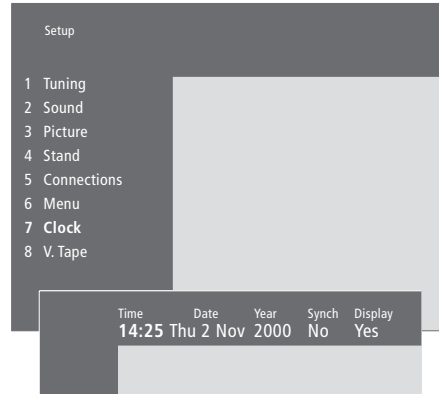

What's on the Clock menu...

TIME

Indicates the time. Enter the current time manually by pressing the number keys on Beo4.

DATE

Indicates the day of the week and the date.

YEAR

Indicates the year.

SYNCH

For synchronisation of the built-in clock with Teletext. Select the current channel by pressing ▲ or ▼ until the channel name is shown. It is only necessary to enter the time manually if SYNCH is set to *No*.

DISPLAY

The following options are available: *YES* (displays the current time whenever Avant is on) and *NO* (displays the time on request). If DISPLAY is set to *NO*, you can see the time in the Avant display by pressing LIST on Beo4 until CLOCK is shown, and then pressing GO.

To set the time and date...

- > Switch on BeoVision Avant and press **MENU** to call up the main menu.
- > Press **4** to call up the *Setup* menu (5 if *Sat* is available).
- > Press **7** to call up the *Clock* menu. *Time* is already highlighted.
- > You can enter the current time by pressing the number keys on Beo4.
- > Press ◀ or ▶ to move through menu items.
- > Press ▲ or ▼ to see your options for a menu item.
- > Press **GO** to store your clock, calendar and display settings, or **EXIT** to leave all on-screen menus.

If the clock is not updated in the transition between Summer and Winter time, simply select the channel with which you originally synchronised the clock.

Abbreviations for month and day of the week

<i>Jan...</i>	January	<i>Jul...</i>	July
<i>Feb...</i>	February	<i>Aug...</i>	August
<i>Mar...</i>	March	<i>Sep...</i>	September
<i>Apr...</i>	April	<i>Oct...</i>	October
<i>May...</i>	May	<i>Nov...</i>	November
<i>Jun...</i>	June	<i>Dec...</i>	December

<i>Mon...</i>	Monday
<i>Tue...</i>	Tuesday
<i>Wed...</i>	Wednesday
<i>Thu...</i>	Thursday
<i>Fri...</i>	Friday
<i>Sat...</i>	Saturday
<i>Sun...</i>	Sunday

Your BeoVision Avant is equipped with a motorised stand which enables you to turn the entire system to the left or right via your Beo4 remote control.

However, you can program BeoVision Avant to rotate automatically on its stand to face your favourite viewing position when you switch on Avant, and turn away to a standby angle when you switch it off.

You can also turn BeoVision Avant to the desired positions by hand.

Preset positions for the TV to turn to

Choose one stand position for when you switch BeoVision Avant on and one for when you switch it off. You can also choose a secondary viewing position, if you have more than one favourite viewing angle.

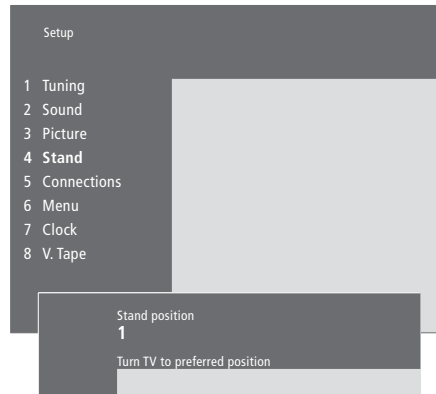

Choose stand position 1 for primary viewing position, 2 for secondary viewing position, or 0 for standby position.

- > Switch BeoVision Avant on and press **MENU** to call up the main menu.
- > Press **4** to call up the *Setup* menu (5 if *Sat* is available).
- > Press **4** again to call up the *Stand* menu.
- > Press **▼** until the appropriate stand position is displayed.
- > Press **◀** or **▶** to rotate Avant to the desired position.
- > Press **GO** to store the position.
- > Repeat the procedure for other stand positions.
- > Press **EXIT** to leave all on-screen menus.

Set your video tape recorder preferences

By entering a set of preferences in a BeoVision Avant fill-in menu, you can program BeoVision Avant to display either the time elapsed during playback or the time remaining on a loaded tape.

You can also preset the video tape recorder to e.g. record your programmes with a particular speed and length.

In addition, you can enter settings that ensure successful recording of programmes even in those cases where the programmes in question are delayed, moved to another time slot or extended.

Avant can also place 'track markers' at the beginning of recordings, thereby making it possible to move directly to a specific recording on a tape.

To gain the full benefit of the functions described for the video tape recorder, you must enter your individual preferences in the video tape recorder's Basic Setup menu.

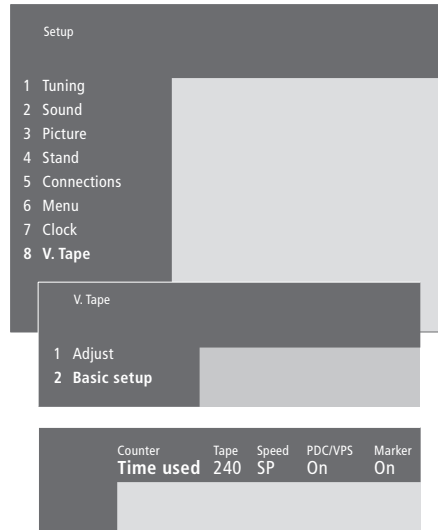

- > Switch on BeoVision Avant and press **MENU** to call up the main menu.
- > Press **4** to call up the *Setup* menu (5 if *Sat* is available).
- > Press **8** to call up the *V. Tape* menu.
- > Press **2** to call up the *Basic Setup* menu.
- > Press **◀** or **▶** to move through menu items.
- > Press **▲** or **▼** to see your options for a menu item.
- > Press **GO** to store your video tape recorder preferences, or **EXIT** to leave all on-screen menus.

What's on the V.Tape Basic setup menu...

Counter (displayed counter indication)

The video tape recorder registers the position on the tape during playback, recording and winding. This information is shown in the BeoVision Avant display. Counter information can be set to either *Time used* (how many hours and minutes the tape has played) or *Time left* (how many hours and minutes of playing time are left on the tape).

Tape (tape length)

The duration of a loaded tape of standard length is registered automatically. If you load a tape of non-standard length, you must enter the length of the tape yourself. Press ▲ or ▼ until the correct tape length is displayed. You can also key in the length (minutes of playing time) using the number keys on Beo4.

Keying in the tape length is useful e.g. if you use non-standard tapes and wish to make use of the 'Time left' counter indication (see above). Tape lengths from 30 to 300 minutes can be entered.

Speed (tape speed)

During playback, the video tape recorder adjusts automatically to the speed at which the tape was recorded. Recordings can be made at two different speeds:

SP (Standard play)

3 hours for an E-180 cassette. Select this speed for optimum picture quality.

LP (Long play)

6 hours for an E-180 cassette. The video tape recorder selects this speed automatically for audio-only recordings.

PDC/VPS (Program Delivery Control/Video Programming System)

The PDC/VPS facility only applies when you program Timer recordings via Teletext. The available options are *On* and *Off*. If the PDC/VPS facility is not cut in, recording will start and stop at the times you have preset, even if the programme is delayed or prolonged. For further information about the PDC/VPS facility, please refer to *Preset a recording from Teletext TV listings* on page 40.

Marker (track identification marks)

Options are *On* and *Off*. Set to *On* if you want to enable the video tape recorder to insert or search for track markers on a tape. This means that each separate recording (track) on the tape will be encoded at the beginning of the recording with a special signal, called a track mark, by which it can later be identified. If you do not want to use track marks, set *Marker* to *Off*.

SECAM sys* (SECAM system – recording)

This item allows you to select the type of SECAM system you prefer to use for recording onto videotapes:

PAL (Standard setting)

Select to achieve a better picture quality on your recordings. When you record a SECAM TV programme, the SECAM signal is transformed into a PAL signal.

SECAM

Ensures that your recordings will be made in accordance with the SECAM system, and should therefore be selected for the recording of SECAM TV programmes.

MESECAM

Should only be selected if you want to be able to play back your recordings of SECAM TV programmes on a PAL video tape recorder. You will then get a modified PAL/SECAM recording on your tapes.

Play sys* (colour system – playback)

This item enables you to manually select a specific colour system when playing back a videotape:

AUTO

The standard setting. Should be selected in most cases as the video tape recorder usually registers the correct type of system quite automatically. *However, to obtain maximum picture quality when playing back a tape, you may have to instruct the video tape recorder to play back a specific tape using exactly the same system as the one in which the tape was recorded. Do not forget to switch back to AUTO afterwards!*

The other options are:

PAL

For your PAL recordings.

SECAM

For your SECAM recordings.

MESECAM

For your MESECAM (Middle East PAL/SECAM) recordings.

*NOTE: The items *SECAM sys* and *Play sys* only appear in BeoVision Avant video systems sold on certain markets.

Adjust picture and sound settings

Picture and sound settings are preset at the factory to neutral values which suit most viewing and listening situations. However, if you wish, you can adjust these aspects to your liking.

You can adjust picture brilliance, colour or contrast. Sound settings include volume, bass, treble, loudness and balance. You can also adjust a BeoLab 2 subwoofer, if it is part of your setup.

You can store your picture and sound settings temporarily – until BeoVision Avant is switched off – or you can store them permanently.

To change the picture format, e.g. from 4:3 to wide screen 16:9, please refer to Home Theatre viewing with Avant on page 48.

Change brilliance, colour or contrast

Adjustment of the picture settings is done via the BeoVision Avant Picture menu. Temporary settings are reset once more to the neutral values when you switch off BeoVision Avant.



- > Switch on BeoVision Avant and press **MENU** to call up the main menu.
- > Press **4** to call up the *Setup* menu (5 if *Sat* is available).
- > Press **3** to call up the *Picture* menu.
- > Press **◀** or **▶** to move between the items on the menu.
- > Press **▲** or **▼** to adjust the settings for each item.
- > Press **EXIT** to store your settings until you switch off BeoVision Avant.
- > Press **GO** to store your settings permanently.

What's on the *Picture* menu...

Brilliance

Picture brilliance can be adjusted in steps of two within a range of 00 to 62; 32 is the neutral setting.

Colour

Colour intensity can be adjusted in steps of two within a range of 00 to 62; 32 is the neutral setting.

Contrast

The contrast level in the picture can be adjusted in steps of one within a range of 00 to 62; 44 is the neutral setting.

For video sources using the NTSC signal a fourth option – Tint (colour shade or nuance) will be available for adjustment.

Change volume, bass, treble or balance

You can adjust sound volume directly on the Beo4 remote control at any time without calling up a menu, but you must call up the Sound menu to be able to adjust bass, treble, loudness or balance.

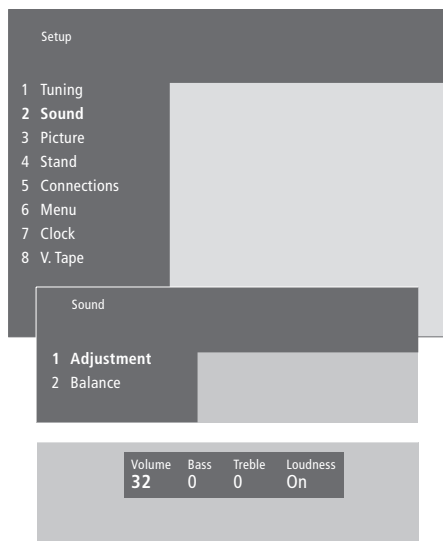

- > Switch on BeoVision Avant and press **MENU** to call up the main menu.
- > Press **4** to call up the *Setup* menu (5 if *Sat* is available).
- > Press **2** to call up the *Sound** menu.
- > Press **GO** to call up the *Adjustment* menu.
- > Press **◀** or **▶** to move between menu items.
- > Press **▲** or **▼** to adjust the settings for each item.
- > Press **EXIT** to store your settings until you switch off BeoVision Avant, or press **GO** to store your settings permanently.

What's on the *Adjustment* menu...

Volume

The volume level can be adjusted in steps of two within a range of 00 to 72.

Bass

Bass tone can be adjusted in steps of one within a range of -6 to +6. 0 is the neutral setting.

Treble

Treble tone can be adjusted in steps of one within a range of -6 to +6. 0 is the neutral setting.

Loudness

Loudness can be set to *On* or *Off*. The loudness function is used to compensate for the human ear's lack of sensitivity to high and low frequencies. It boosts the low and the high frequencies when you are listening to low volume levels so that the music becomes more dynamic.

Subwoofer

(only available if you have connected a BeoLab 2 subwoofer to BeoVision Avant). Can be adjusted in steps of one within a range of -9 to +9. 0 is the neutral setting.

What's on the *Balance* menu...

Balance

The speaker balance can be adjusted by a maximum of 6 steps to the left or to the right.

> < is the neutral setting.

To adjust speaker balance temporarily between the five speakers in a surround sound setup, please refer to 'Home Theatre viewing with Avant' on page 48 for more information.

*NOTE! If your BeoVision Avant is equipped with a surround sound module, the *Sound* menu lets you calibrate your surround sound speaker setup permanently. Please refer to *Loudspeaker connections – surround sound* on pages 9–12 for further instruction.

Daily operations

The operations shown on this page are functions you will use daily:

- Choose a TV or Satellite* channel by its number;
- Switch to another channel or source;
- Call a channel list up on the screen;
- Adjust the position of BeoVision Avant on its motorised stand;
- Adjust the sound volume or sound type.

All of these functions can be performed via the Beo4 remote control, though you can also adjust TV position by hand.

Select a TV or Satellite channel

To watch a TV or Satellite channel, press the appropriate button on Beo4. BeoVision Avant switches on the last channel you watched.

While BeoVision Avant is off...

TV	Press TV or SAT to switch on a source. The last channel viewed appears on the screen
TV2	
0 – 9	Press a channel number to go directly to that channel
▲	Press ▲ or ▼ to change channels one by one
▼	
SAT	Press another source button at any time to switch on that source
•	Press to switch off BeoVision Avant

See a channel list

All your TV and Satellite channels appear on separate lists, which you can call up on the screen. The lists contain channel numbers and names. The lists can contain 99 TV channels and 119 Satellite channels.



The TV channel list. Dotted lines show that a channel has been stored, but not named. An empty slot in the list shows that no channel has been stored there.

TV	Press TV or SAT to switch on a source
GO	Press and hold GO to call up a channel list on the screen
◀ ▶	Press ◀ or ▶ to view the previous or following page of the channel list
0 – 9	To select a channel to watch, press the channel number on Beo4 or press ▲ or ▼ until the cursor is on the desired channel
▲	
▼	
GO	To switch on the chosen channel, press GO, or press EXIT to leave the menu
EXIT	

You can also call up the channel list by pressing MENU to call up the main menu and pressing either 3 or 4 to select the appropriate list.

*NOTE! Satellite channels are only available if your BeoVision Avant is equipped with the built-in Satellite receiver module.

Adjust viewing position

You can turn the television on its built-in motorised stand via Beo4.

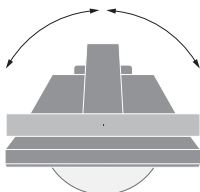

- LIST**
STAND
- Press LIST on Beo4 until STAND is shown in the Beo4 display window
- ◀ ▶ Press ◀ or ▶ to turn BeoVision Avant to the left or right, or...
- 0** ...press 0, 1 or 2 if you have
1 preset viewing positions for your
2 television

Please refer to page 31, 'Set positions for viewing and standby', for more information about how to preset positions for TV viewing.

Adjust or mute the sound volume

You can adjust or mute television sound at any time while you are using a source.

While BeoVision Avant is on...

- ^ Press either end of the button to adjust the volume up or down
- ∨
- Press the middle of the button to mute the sound
- ^ Press either end of the button to bring the sound back
- ∨

Change sound type* or language

The various types of sound which are available will be shown on the BeoVision Avant display as you proceed.

While BeoVision Avant is on...

- LIST** Press LIST on Beo4 until SOUND is displayed
- GO** Press GO to see the current sound type in the Avant display
- STEREO**
- GO** Press GO repeatedly to switch to another sound type or language in a multi-language programme
- GO**
- EXIT** Press to exit the SOUND function

In order to display SOUND in the Beo4 display, you must first add it to the Beo4 list of functions. Please refer to 'Gain access to extra functions via Beo4' on page 59 for more information.

*NOTE! You can store your favourite sound type when tuning in your TV or Satellite channels. Please refer to *Edit tuned TV or Satellite channels* on pages 24–29 for further instruction.

Load and play a videotape

All operation of the video tape recorder, apart from loading and unloading of a tape, is done via the Beo4 remote control.

You can play, pause and stop a loaded tape, rewind and fast forward, or cue the tape backwards and forwards at two speeds. You can also choose to play a tape in slow motion.

Finally, you can adjust the tape tracking, picture sharpness or picture stability if the tape you play in the BeoVision Avant video tape recorder results in irregularities in the picture quality.

Load a videotape

Loading and unloading of videotapes is done manually via the loader on the front and the close-up operation panel on the back of BeoVision Avant.

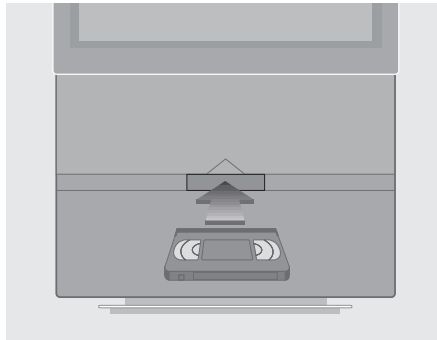

- > Push the tape under the loader cover into the compartment in the centre below the screen.
- > Let go of the tape when you feel the mechanism drawing the tape into the compartment.
- > Press the **EJECT** button on the operation panel behind the BeoVision Avant display bar to unload a tape.

Never leave a tape in the compartment opening! The open flap keeps the system alert and thus wastes energy. The flashing standby indicator will prompt you to load or unload the tape.

Play or stop a tape

You can play a tape by switching on the video tape recorder. The tape recorder will play the tape to the end, rewind it and shut itself off automatically, unless you give other instructions

When you have loaded a tape...

V TAPE

1:30

Press the V TAPE button on Beo4 to switch on the video tape player and start playing a tape. Either the time elapsed or time remaining will appear on the display bar*

STOP

Press to pause the tape

GO

Press to resume playing the tape, or...

STOP

...press to stop the tape completely

- Press to switch off the video tape recorder. If the video tape recorder is left unused for more than eight minutes, it switches itself off automatically

If you are playing an NTSC tape, pressing STOP once will cause the tape to stop playing completely, and the counter position will not appear in the display.

*NOTE! Refer to *Set your video tape recorder preferences* on page 32 for more information about how to choose a display preference for the video tape recorder.

Search through a tape

Via Beo4, you can cue forwards and backwards through a tape, play in slow motion, rewind and fast forward. You can also rewind via the control panel behind the Avant display bar.

While BeoVision Avant is on...

 Press the green or yellow buttons on Beo4 to cue backwards or forwards through a tape. The display bar shows your cue speed

< CUE

CUE >



Press again to change speed

 Press the red or blue buttons on Beo4 to play the tape backwards or forwards in slow motion. The display bar shows your speed

<< SLOW

SLOW >>

Press again to change speed

 Press  or  to rewind or fast forward. The display bar shows the time elapsed or the time remaining

<< 1:30

STOP Press to stop the tape, or...

GO ...press to resume playback of the tape

If you are playing an NTSC tape, you will not be able to play your tape in slow motion and counter position will not appear in the display.

Adjust tape tracking, sharpness and 'jitter'

Picture streaks or unclear sound can occur when you play prerecorded tapes or tapes recorded on another video tape recorder. The cause may be imprecise videotape tracking. Avant lets you adjust tracking, picture clarity and 'jitter'.

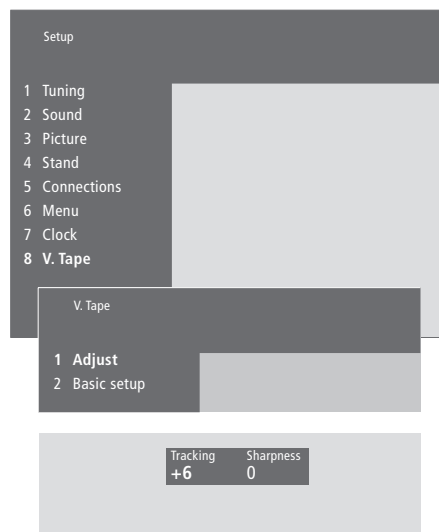

'Tracking' is the process by which the video tape is fed through the machine reels. 'Sharpness' indicates how clear and defined objects in the picture are, and 'jitter' refers to unsteadiness in the picture when playback is paused.

- > Press **MENU** to call up the main menu.
- > Press **4** to call up the *Setup* menu (5 if *Sat* is available).
- > Press **8** to call up the *V. Tape* menu. *Adjust* is already highlighted.
- > Press **GO** to call up the *Adjust* menu.
- > Press **▲** or **▼** to adjust tracking within a range of -18 and +18.
- > To adjust picture clarity, press **▶▶** to move to *Sharpness* and then press **▲** or **▼** to adjust it within a range of -3 and +3.
- > To adjust jitter, pause the tape and call up the *Adjust* menu. Move the cursor to *Jitter* and press **▲** or **▼** to adjust it within -18 and +18.
- > You can adjust tracking via Beo4 without calling up the menu. Press **LIST** until **TRACKNG** is shown in the Beo4 display*, and then press **▲** or **▼** to adjust tracking.

*NOTE! In order to display **TRACKNG** on Beo4, you must add the function to the Beo4 list of functions. Please refer to *Gain access to extra functions via Beo4* on page 59 for further instruction.

Recording

With BeoVision Avant, you can preset a recording of a programme to occur at a particular time on a particular date.

If PDC/VPS (Program Delivery Control/Video Programming System) signals are broadcast by the current channel, BeoVision Avant can ensure that a programme is recorded in full*, even if the broadcast time is changed by the broadcaster.

You can change settings for a Timer recording or delete it entirely. Up to eight Timer recordings can be preset.

You can, of course, record a programme here and now. Unless you give other instructions, the video tape recorder will record until the tape runs out.

If you wish to enter timer settings, the built-in clock must be set to the correct time. Please refer to *Set the time and date* on page 30 for more information.

Finally, you can copy videotapes, as well as record sound e.g. from a radio programme.

Preset a recording from Teletext TV listings

You can preset a recording of a future programme from a Teletext TV listings page.



Note about PDC/VPS and recording...

If PDC (Program Delivery Control) or VPS (Video Programming System) signals follow the broadcast programs you record, and the PDC/VPS facility is set to *On* in Avant's *V.Tape Basic Setup* menu, then the title of the programme you want to record will be highlighted instead of the start time. There is no need to consider start and stop times, just accept the status line which appears instead of the programme title. If necessary, you can, of course, change the information displayed.

When the PDC or VPS system is used, it means that the broadcaster attaches a coded signal to every programme they broadcast, ensuring that a recording will be recorded in full, even though the broadcasting of the programme in question was delayed, causing start and stop times to change.

While the TV is on...

- > Press **TEXT** to call up Teletext.
- > Locate the Teletext TV listings page.
- > Press **RECORD**. A cursor will highlight the first programme name or start time on the list.
- > Press **◀▶** or **▼** to move the cursor to the programme you wish to record.
- > Press **GO** to select that program. The cursor highlighting the programme will change to show the date, the channel number and channel name, followed by 'OK?'.
- > If this information is incorrect, press **◀** or **▶** to move through the information and **▲** or **▼** to change the settings.
- > Press **GO** to store your preset Timer recording. **RECORD** is shown.
- > If you want to record more programmes, you can continue to highlight listed programmes with the cursor.

If PDC/VPS signals are not broadcast by the current channel, your recordings are then preset by start and stop times, and will not adapt to broadcast delays or extensions. You will see the times at the top of the screen when you store a programme to be recorded.

*NOTE! The PDC/VPS option on the *V.Tape Basic Setup* menu must be set to *On* for Avant to record a delayed or extended broadcast. Please refer to *Set your video tape recorder preferences* on page 32 for information about the *V.Tape Basic Setup* menu.

Preset a Timer recording manually

You can preset a recording to start and stop automatically at any time you choose. You can record TV and Satellite programmes, as well as radio programmes from any compatible Bang & Olufsen audio system you have connected.



To enter settings for a Timer recording...

- > Switch on the system and press **MENU** to call up the main menu. *Timer record* is already highlighted.
- > Press **GO** to call up the *Timer record* menu.
- > Press **◀** or **▶** to move through menu items.
- > Press **▲** or **▼** to see your options for a menu item.
- > Press the number keys on Beo4 to fill in e.g. a program number or start and stop times.

To preset a Timer recording for certain days of the week...

- >...press **▶** to highlight *Date* and then press **MENU** to change *Date* to *Days*.
- > When you have filled in the required information, press **GO** to store your timer settings, or **EXIT** to leave all on-screen menus.

If you have preset eight Timer recordings, and attempt to call up the Timer record menu, the 'Timer index' will be shown. You must delete an existing Timer recording to be able to enter a new one.

What's on the *Timer record* menu...

Source

Indicates the source you wish to record from.

Options* are:

TV

For recording of TV programmes.

SAT

For recording of Satellite programmes. If your BeoVision Avant does not have a built-in Satellite receiver, but it does have a Set-top Box Controller, you can then select SAT to preset a Timer recording from a connected set-top box.

RADIO

For recording of radio programmes from a connected Bang & Olufsen audio system.

AV

For recording from external equipment connected to the AV socket on BeoVision Avant.

V.AUX

For recording from e.g. a set-top box or other connected equipment.

Pr (Program number)

Once your source is chosen, choose the program number you want.

Start and Stop (Start and stop times)

Key in the times you want the recording to start and stop. Key in e.g. **2100** for 9 pm and **2200** for 10 pm.

Date or Days

Fill in the date you want the recording to take place. Alternatively, press **MENU** to change *Date* into *Days*. Select the specific weekday(s) on which you want your recording executed. All the weekdays will be displayed – starting with M for Monday. Press **▶** to move through the days and press **▼** to remove any day you do not want. When the weekday(s) you want are displayed, press **GO** to accept the day(s) and move on to *OK*.

The system writes:

<i>Jan...</i>	January	<i>Jul...</i>	July
<i>Feb...</i>	February	<i>Aug...</i>	August
<i>Mar...</i>	March	<i>Sep...</i>	September
<i>Apr...</i>	April	<i>Oct...</i>	October
<i>May...</i>	May	<i>Nov...</i>	November
<i>Jun...</i>	June	<i>Dec...</i>	December

<i>Mon...</i>	Monday
<i>Tue...</i>	Tuesday
<i>Wed...</i>	Wednesday
<i>Thu...</i>	Thursday
<i>Fri...</i>	Friday
<i>Sat...</i>	Saturday
<i>Sun...</i>	Sunday

OK

When *OK* is highlighted, press **GO** to store your preset Timer recordings.

*NOTE! The sources shown appear only if they are actually present in your BeoVision Avant setup.

See a list of scheduled recordings

The *Timer index* list of pending recordings allows you to check whether or not recordings conflict with each other. You can change channel, date, or time for recordings, or delete them altogether.

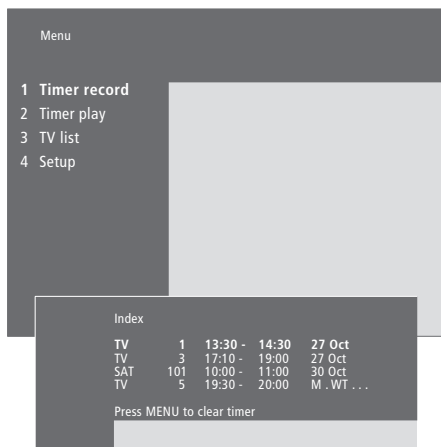

Check the status of scheduled recordings

- > Switch on the system and press **MENU** to call up the main menu on the screen.
- > Press **GO** to call up the *Timer record* menu.
- > Press **◀** to move the cursor to either *Source* (source) or *Pr* (program) and press **MENU** to call up the *Timer index*.

To edit a Timer recording...

- > When you have brought up the *Timer index* on the screen, press **▼** to move the cursor down to a desired recording and press **GO**.
- > Press **◀** or **▶** to move through the settings, and **▲** or **▼** to change them. You can also enter numeric settings by pressing the number keys on Beo4.

To delete a recording...

- > Call up the *Timer index* on the screen and highlight a Timer recording.
- > Press **MENU**. *Clear?* is shown instead of a recording date.
- > Press **GO** to delete the Timer recording, or **EXIT** to keep it.

Record here and now

If you want to record the programme you are currently viewing, or a programme about to begin, you can start recording immediately. You can also watch another TV programme or switch Avant to standby while recording.

- > Press **RECORD** twice. The video tape recorder will begin recording on the current TV or Satellite channel.
- > To watch another programme during recording, just select the desired TV programme on Beo4. If you record a Satellite programme, it is not possible to watch other Satellite programmes than the one being recorded.
- > Press **V.TAPE** and then **STOP** to pause recording.
- > Press **RECORD** again to resume a paused recording.
- > Select a new source, such as **TV** or **SAT**, to stop a paused recording completely and watch another programme.
- > Press **•** to switch the system to standby. Your recording will continue, unless it is paused when you switch Avant to standby. A paused recording will then stop completely.

If you call up the 'Timer record' menu while watching a TV programme, the video tape recorder will offer to record the current programme – starting immediately and continuing for one hour. If the current programme runs for more than one hour, you can change the stop time as described on page 41. Press GO to start recording.

Copying videotapes

Via the AV socket on the back of BeoVision Avant and the Beo4 remote control, you can copy tapes directly from an extra video tape recorder onto a tape in the Avant video tape recorder.

- > To start a second video tape player, press LIST on Beo4 until V.TAPE2 is shown in the Beo4 display, and then press GO.
- > Press RECORD to prepare Avant for recording.
- > Press RECORD again to start recording.
- > Press V TAPE and then STOP to pause a recording.
- > Press RECORD to resume a paused recording.
- > Press TV or any other source button to stop recording completely.

While copying takes place, you can watch a TV programme or switch off the TV. Press V TAPE on Beo4 to return to the copying process.

Connect the extra video tape recorder to the AV socket and register it in the BeoVision Avant Connections menu. Please refer to *Connect other equipment* on page 15 and *Register extra equipment* on page 20 for further instruction.

Record sound alone

The Avant video tape recorder can record sound without pictures, like a Satellite radio programme. The recorded sound is of very high quality. Audio recordings can also be made from a connected Bang & Olufsen audio system.

Record from a connected audio system

There are two methods of recording sound from your Bang & Olufsen audio system on videotape. The method you use depends on the way your Bang & Olufsen audio system is connected to and used with the BeoVision Avant: The two methods are described to the right.

Record a Satellite radio programme

To record Satellite radio programmes on videotape, just switch on the programme and press RECORD twice on Beo4 to start recording, as described to the right under 'Method 1 – Audio and video system'.

Method 1 – Audio and Video system

Your speakers are connected to the audio system. For more information about using such a setup, please refer to *Use an integrated audio/video system* on page 53.

- > Press LIST until AV* is displayed.
- > Press a source button, such as RADIO or SAT, to start playing the audio source you wish to record.
- > Press RECORD to prepare Avant for recording.
- > Press RECORD again to start recording.

Method 2 – Surround sound AV system

Your speakers are connected to the BeoVision Avant. For more information about using this setup, please refer to *Home Theatre viewing with Avant* on page 48.

- > Press a source button, such as RADIO, to switch on the source you wish to record.
- > Press LIST until AV* is displayed.
- > Press RECORD to prepare Avant for recording.
- > Press RECORD again to start recording.

For both Method 1 and 2, you can pause the recording by pressing V TAPE followed by STOP. Press RECORD to resume recording, or a source button, such as TV, to stop recording completely.

**In order to display AV on Beo4, you must add the function to the Beo4 list of functions. Please refer to 'Gain access to extra functions via Beo4' on page 59 for further instruction.*

Look up Teletext information

Teletext is an information system in video form used by broadcasters to transmit news, weather forecasts and other information of general interest.

If you select a channel that offers a Teletext service, BeoVision Avant gives you access to Teletext pages. Sometimes a single page will consist of several subpages, which appear one by one in a repeating series.

If your Teletext broadcaster offers a Fastext service, you can use the coloured buttons on Beo4 to step to one of four linked Teletext pages.

Store your most frequently used Teletext pages as memory pages. These appear first when you switch on Teletext, thereby saving you time.

If you save the Teletext subtitles page as memory page number four, you can activate subtitles for that particular channel automatically.

BeoVision Avant can also notify you when a desired page has been found or updated.

Main Teletext functions

The index on Teletext page 100 outlines the major categories of Teletext information and lists their page numbers to make information easy to locate. For example, news may start on page 110, sports on page 200 or TV listings on page 300.



A typical Teletext page. The current page number, channel name, date and time appear at the top of the screen, as well as a three-digit number showing the progress of the page search function.

While BeoVision Avant is on...

TEXT	Press to see the Teletext index page
0 – 9	Press the number of a Teletext page you want to see
▲	Press to turn pages
▼	
STOP	If the current page contains subpages, you can either view them in their turn, or press STOP to pause subpage turning
0 – 9	To view a particular subpage, enter the four-digit code of the desired page, or press ▲ or ▼ to step to the page
▲	
▼	
STOP	Press STOP again to resume subpage turning
EXIT	Press to leave Teletext and return to viewing your source

Enlarge the screen text size

- > Press **LIST** on Beo4 until **LARGE** is displayed and then **GO**. The upper half of the current page is shown.
- > Press **GO** again to view the lower half.
- > Press **GO** a third time to restore the normal text size.

To keep the TV picture in Teletext

- > Press **LIST** on Beo4 until **MIX** is shown and then **GO** to superimpose Teletext information on the TV picture.
- > Press **GO** again to remove the TV picture.

To reveal hidden text

- > Press **LIST** on Beo4 until **REVEAL** is shown and press **GO**. If there is concealed text on that page, it will become visible.
- > Press **GO** again to remove the revealed text.

Store frequently read pages

If you use some Teletext pages frequently, e.g. TV listings, we recommend that you preset these pages as memory pages* in order to gain access to them more easily. You can preset up to four memory pages per Teletext service.

0 – 9 ▲ ▼	From Teletext, press the number keys on Beo4 to enter the number of a page you refer to often. You can also press ▲ or ▼ to turn to that particular page
LIST STORE	Press LIST on Beo4 until STORE is shown in the Beo4 display
GO	Press GO to select the current page for storing
1 – 4	Press the number keys on Beo4 to enter the number of the memory page to be used
GO	Press GO to store the page or...
EXIT	...press EXIT to leave the STORE function and return to Teletext

Please note that set-top box Teletext pages can be viewed, but not stored as memory pages!

Day-to-day use of memory pages

You may need to refer to your Teletext memory pages quickly, e.g. if you are leaving for work and wish to check traffic information on a Teletext service.

TV SAT	Press to turn on a TV or Satellite channel which offers a Teletext service
TEXT	Press to switch on Teletext. The page stored as memory page 1 appears automatically
◀ ▶	Press ◀ or ▶ to view the other memory pages

To view stored memory pages from another channel's Teletext service, press EXIT on Beo4 to return to channel viewing, press ▲ ▼ or the channel number to change channels, and press TEXT to switch on Teletext.

Activate subtitles from Teletext

If a channel offers Teletext subtitles, you can activate subtitles for that channel. The Teletext subtitles page number can often be found in an index on Teletext page 100.

<i>While BeoVision Avant is on...</i>	
TEXT	Press to switch on Teletext
▲ ▼ 0 – 9	Press ▲ ▼ or the number keys on Beo4 to locate the Teletext subtitles page. Subtitles appear on the screen
EXIT	Press to cancel subtitles

To store subtitles permanently from the Teletext subtitles page...

LIST STORE	Press LIST on Beo4 until STORE is shown in the Beo4 display
GO	Press GO to select the page
4	Press 4 to store the subtitles page
	To cancel stored subtitles, simply store another Teletext page as memory page number 4
TV	Press TV to return to TV viewing

*NOTE! If your BeoVision Avant is linked via BeoLink to another television, stored memory pages will not be shared among linked televisions. Memory pages must be stored manually on all linked televisions.

See updated Teletext pages

BeoVision Avant supports the page update function, provided by some Teletext broadcasters to announce that a Teletext page has been updated. This is useful e.g. if you want to see the latest news headlines while watching TV.





Call up the relevant Teletext page...

LIST	Press until UPDATE is shown in the Beo4 display
UPDATE	
GO	Press to switch on the UPDATE function
FOUND	When the page is found, FOUND appears on the screen
UPDATE	When the page has been updated, UPDATE appears on the screen
GO	Press to see the located or updated page
EXIT	Press to leave Teletext

Go directly to a page via Fasttext

Some Teletext broadcasters offer immediate access facilities, called Fasttext, that enable you to step directly to one of four linked Teletext pages. Fasttext is supported by the BeoVision Avant.

While the TV is on...

TEXT	Press TEXT on Beo4 to switch on Teletext
▲ ▼ 0 – 9	Press ▲ or ▼ to find a Fasttext page. Alternatively, enter the page number using the number keys
 	Press one of the coloured buttons on Beo4 to gain access to the Fasttext facility. The titles of the four linked pages appear at the top of the screen
 	Press the coloured button which corresponds to the linked page you wish to see
TEXT	Press to leave Fasttext and return to normal Teletext viewing, or...
EXIT	...press to leave Teletext completely



A Teletext page with the colour bar at the top right indicating that it is a Fasttext page.



The titles of the four linked pages appear at the top of the activated Fasttext page, each with their own colour.

The Picture-in-Picture function* enables you to see two video sources on-screen simultaneously. For example, you can view two different TV programmes, a TV and a Satellite programme, a TV and a set-top box programme or a videotape playback and a TV programme at the same time.

Picture within a picture

While you are watching a programme or recording, you can prompt your BeoVision Avant to insert a small picture on the screen showing the source and channel number of your choice.

While watching e.g. TV...

LIST Press LIST on Beo4 until P-IN-P is shown in the Beo4 display

P-IN-P

P-V.AUX To view a source registered in the Connections menu as V.AUX, such as a set-top box, press LIST until P-V.AUX is shown in the Beo4 display instead

SAT Press e.g. SAT to select a source to view in the window
The sound follows the large picture, but your Beo4 commands are now directed to the window

0 Press 0 to swap the large and small picture

LIST To place the window on the screen, press LIST until P-IN-P is displayed, followed by the coloured button corresponding to a corner of the screen



TV Press a source button, such as TV, to cancel Picture-in-Picture and return to normal viewing, or...

• ...press • to switch BeoVision Avant to standby

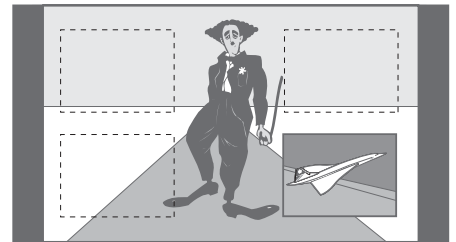
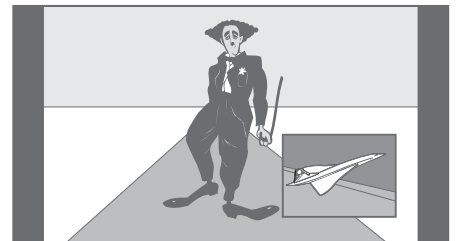
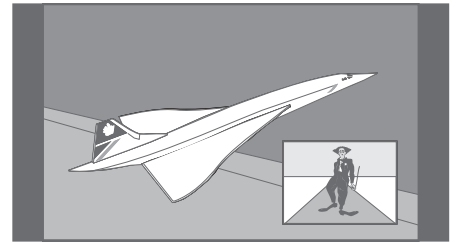

If P-IN-P is not available on the Beo4 display, you must add it to the Beo4 list of functions. Please refer to 'Gain access to extra functions via Beo4' on page 59.

*NOTE! The Picture-in-Picture function requires that your BeoVision Avant is equipped with the built-in Picture-in-Picture module.

Home Theatre viewing with Avant

If your BeoVision Avant is equipped with a surround sound module, you can extend your system into a fully equipped Home Theatre system by connecting four Bang & Olufsen speakers and a BeoLab 2 subwoofer.

Please refer to *Connect speakers for surround sound* on pages 9-12 for more information about how to connect speakers to BeoVision Avant.

When you switch on one of your sources in your BeoVision Avant, the speakers which you may have in a surround sound system can be cut in or out, depending on what kind of sound suits the source you are using.

BeoVision Avant may switch on a speaker combination automatically. This happens if a broadcasted programme or DVD disc contains information about the number of speakers to be switched on. You are still free to choose the speaker setup you prefer.

You can also adjust the picture dimensions to fill out the screen and complete the Home Theatre experience.

Select speakers for movie sound

While you are watching a movie or programme, you can choose the speaker combination you wish to switch on, provided that the various sound modes are available in your system.

To choose a speaker option via Beo4

LIST

Press LIST on Beo4 until

SPEAKER

SPEAKER is displayed

1 – 5

Press the number of the speaker option you want. The speakers selected will cut in automatically



If you want to adjust the sound balance for the programme you are watching, press ▲ or ▼ to adjust the balance between the external front and rear speakers, and press ◀ or ▶ to adjust the balance between the left and right speakers



EXIT

Press to remove SPEAKER from the Beo4 display and to return to the source you were using

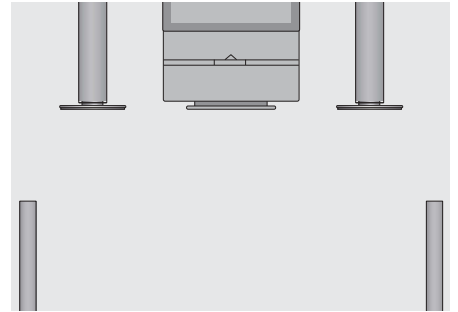

Speaker combinations

SPEAKER 1

Stereo sound in Avant speakers only. For programmes with dialogue, e.g. TV news.

SPEAKER 2

Stereo sound in the two external front speakers. For music CDs.

SPEAKER 3

Avant speakers and external front speakers active. For TV programmes in stereo.

SPEAKER 4

Enhanced stereo sound in the external front and rear speakers. For music CDs or tapes.

SPEAKER 5

Surround sound from all speakers. For programmes in Dolby Surround Sound.

If you have connected only two external front speakers to BeoVision Avant, you will only be able to choose SPEAKER 1–3.

Make the picture fill out the screen

BeoVision Avant always ensures you the best possible picture. It automatically adapts the picture so that it fills out as much of the screen as possible. However, you can still choose a preferred format for Home Theatre viewing.

To choose a format...

- LIST** Press LIST on Beo4 until
- FORMAT** FORMAT is shown

- GO** Press if you want BeoVision Avant to optimise the picture, otherwise...

- 1 – 3** ...press the number of the desired picture format

- ▲** If you have chosen Format 1, press **▲** or **▼** to select variations of this format
- ▼**

- ▲** Press to move the picture up and down if you have chosen Format 2
- ▼**

- EXIT** Press to leave the picture format function

Picture formats to choose from

- FORMAT 1**
For standard TV pictures, as shown to the right. Three variations are available: 15:9 (for the largest picture), 14:9 and 4:3 (for standard picture format).
- FORMAT 2**
For letter-box pictures.
- FORMAT 3**
For 16:9 wide-screen pictures. **FORMAT 3** will usually be selected automatically. If this is not the case, you can select it yourself.

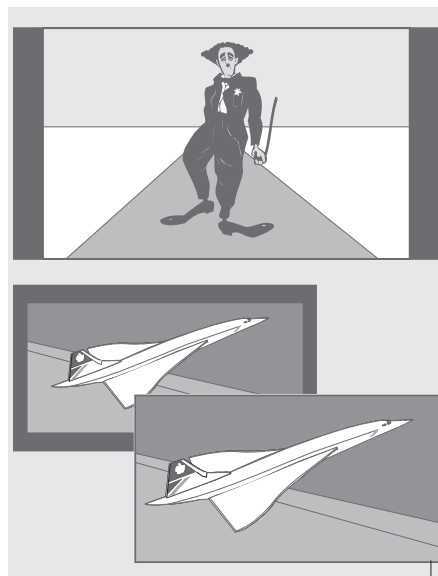

The illustration at the top shows the BeoVision Avant standard picture format, which is a 15:9 format.

The two illustrations above show what happens to a letter-box picture when you choose format 2. The picture is adapted to fill out more of the screen.

Switch Avant on or off automatically

You can preset BeoVision Avant to switch itself on or off automatically by programming a built-in timer.

You can preset the timer to switch BeoVision Avant on or off on a specific date and time, or at the same time and day from week to week.

You can enter as many as eight timer settings, and call up an on-screen list of the timer settings you have entered. From this list, you can edit or delete your timer settings.

If you wish to enter timer settings, make sure that the built-in clock is set to the correct time. Please refer to *Set the time and date* on page 30 for further information.

To see how to program your system to start and stop recording automatically, please refer to the chapter entitled *Recording* on pages 40–43.

Timer play and timer standby

Use the Timer play function if e.g. there is a programme you do not want to miss, or if you want a morning wake-up call. Use Timer standby if e.g. you want to make sure Avant is switched off when you leave for work in the morning.

Before you start...

Make sure to switch on the Timer Play function before you begin entering timer settings. Press the PLAY TIMER button on the back of the BeoVision Avant display bar to switch on the Timer Play function. PT is then shown in the display. To switch off the Timer Play function, press the PLAY TIMER button again.

If your audio system is integrated with BeoVision Avant, and you wish to listen to the radio through speakers connected to the audio system, the audio system's Timer play function must first be switched on. You can then enter Timer play settings for the audio system via BeoVision Avant. Please refer to the User's guide for the audio system you have connected.



The Timer Play menu. To see previously entered timer settings, press MENU...

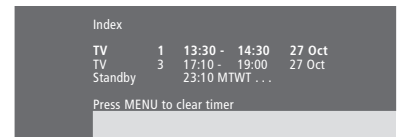

...and the Timer index appears. Here you can edit or delete your previously entered timer settings.

To enter *Timer Play* or *Timer standby settings*...

- > Switch on the system and press **MENU** on Beo4 to call up the main menu.
- > Press **2** to call up *the Timer play menu*.
- > Press **◀** or **▶** to move through menu items.
- > Press **▲** or **▼** to see your options for a menu item.
- > Press the number keys on Beo4 to fill in e.g. a program number or start and stop times.
- > If you want to set *Timer Play* for certain days of the week, press **▶** to highlight *Date* and then press **MENU** to change *Date* to *Days*.
- > When you have filled in the required information, press **GO** to store your timer settings, or **EXIT** to leave all on-screen menus.

To view, edit or delete your *Timer Play settings*...

- > Press **MENU** on Beo4 while *Source* (source) or *Pr* (program) is highlighted to call up a current *Timer index* of previously entered timer settings.
- > Press **▼** or **▲** to move through the list to a setting you wish to edit or delete.
- > To edit a setting, press **GO** and follow the procedure described above.
- > To be able to delete a setting, press **MENU**. The date will be replaced by *Clear?*
- > Press **GO** to delete the setting, or **EXIT** to keep it.

What's on the *Timer Play* menu...

Source

Depending upon the option you choose, *Source* indicates either that a specific Avant source is to be switched on or that BeoVision Avant is to be switched off. Options* are:

TV

To switch on the TV.

SAT

To switch on satellite TV.

V.TAPE

To switch on the video tape recorder.

CD

To switch on the CD player.

A.TAPE

To switch on the audio tape recorder.

RADIO

To switch on the radio.

STANDBY

To switch the BeoVision Avant off. Note that if you have other compatible video or audio systems connected to your BeoVision Avant, they will be switched off as well, even if you have programmed these systems to play.

Pr (Program number)

Once your source is chosen, choose the program number you want.

Start and Stop (Start and stop times)

Key in the times when you want the system to start and/or stop playing. If you have chosen STANDBY as your source (for *Timer standby*), then enter only the stop time.

Date or Days

Fill in the date you want the system to start playing or switch off. Alternatively, press **MENU** to change *Date* into *Days*. Select the specific weekday(s) on which you want your *Timer* executed. All the weekdays will be displayed – starting with M for Monday. Press **▶** to move through the days and press **▼** to remove any day you do not want. When the weekday(s) you want are displayed, press **GO**. OK is then highlighted.

The system writes:

<i>Jan...</i>	January	<i>Jul...</i>	July
<i>Feb...</i>	February	<i>Aug...</i>	August
<i>Mar...</i>	March	<i>Sep...</i>	September
<i>Apr...</i>	April	<i>Oct...</i>	October
<i>May...</i>	May	<i>Nov...</i>	November
<i>Jun...</i>	June	<i>Dec...</i>	December

Mon... Monday

Tue... Tuesday

Wed... Wednesday

Thu... Thursday

Fri... Friday

Sat... Saturday

Sun... Sunday

OK

When OK is highlighted, press **GO** to store your *Timer play* or *Timer standby* settings.

*NOTE! You can only select the options listed if the source is present in your BeoVision Avant setup. If RADIO is available, CD and A.TAPE will also appear, regardless of whether they are actually present or not.

Use an integrated audio/video system

If you connect your Bang & Olufsen audio system to your BeoVision Avant and have a pair of speakers connected to the audio system, you can obtain the benefits of an integrated audio and video system.

You can listen to any source you like on the speakers of either system. You can, for example, listen to a music video through your audio system speakers while you watch it on the TV screen; you can play the radio or any other audio source on the BeoVision Avant speakers.

To enable integration of your BeoVision Avant and Bang & Olufsen audio system, you must connect the two systems with a special BeoLink cable, available through your Bang & Olufsen retailer*. Please note that not all Bang & Olufsen audio systems support integration with BeoVision Avant.

If you have a surround sound system in which your audio system is linked to Avant and there are front and rear speakers connected to the Avant, please refer to *Home Theatre viewing with Avant* on page 48.

Use audio or video system speakers

Integrating your audio system and BeoVision Avant lets you choose speakers appropriate to the current video or audio programme, and also makes it possible for you to record both video and audio sound on either system.

Play audio or video sound on either system

LIST

AV

To listen to sound from an Avant source on your audio system speakers without switching on the screen, press LIST until AV* is displayed...

TV

...then press a source button, such as TV

If you press the source button before pressing LIST as well as after AV is displayed, the screen will be switched on.

LIST

AV

RADIO

To play audio sound on the Avant speakers, press LIST until AV* is shown, followed by an audio source button, such as RADIO

**In order to display AV on Beo4, you must first add it to the Beo4 list of functions. Please refer to 'Activate extra features via Beo4' on page 59 for further instruction.*

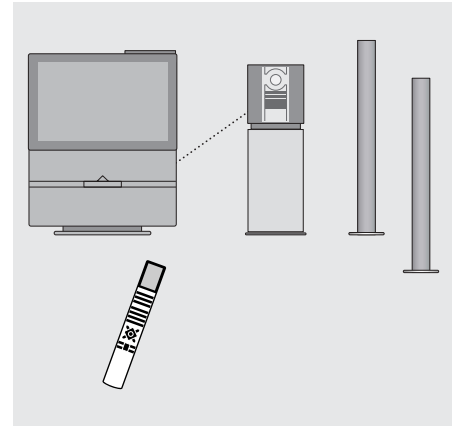

Audio/video recording

The sound you hear on the BeoVision Avant speakers can be recorded on the video tape recorder as a 'sound only' recording. Please refer to *Record sound alone* on page 43 for further instruction.

If you listen to sound from your BeoVision Avant on your Bang & Olufsen audio system's speakers, and if your audio system has a tape recorder, you can record Avant sound on the audio tape recorder. Please refer to the User's guide enclosed with your audio system for further instruction.

***NOTE!** To display LINK or AV on your Beo4 remote control, you must add it to the Beo4 list of functions. Please refer to 'Gain access to extra functions via Beo4' on page 59 for further instruction.

You can watch and listen to all of your available sources on a BeoVision Avant placed in a link room, including video and audio sources from the main room.

Timer play or Timer standby settings, as described on page 50, can also be executed on a link room BeoVision Avant, but must be programmed from the system in the main room.

Please refer to *Set up BeoVision Avant in a link room* on page 18 for more information about how to connect a BeoVision Avant for use in a BeoLink system.

Use main room and link room sources

If you have BeoLink installed in your home and choose to place your Avant in a link room, just operate your Avant as if it were placed in a main room.

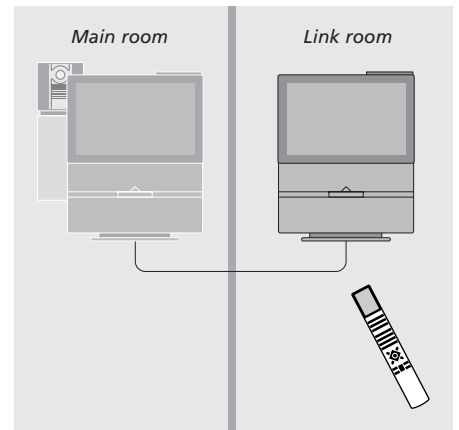

Use sources only present in one of the rooms

- RADIO** Press the button for the source you wish to use
- A TAPE**

Operate the selected source as usual

Use a main room source – source type present in both rooms

- LIST** Press LIST on Beo4 until LINK* is shown in the Beo4 display
- LINK**

- TV** Press the button for the source you wish to use
- V TAPE**

Operate the selected source as usual

Use a link room source – source type present in both rooms

- TV** Press the button for the source you wish to use
- V TAPE**

Operate the selected source as usual

If you use the Picture-in-Picture function in a link room Avant, your viewing options are limited to those sources actually available in the link room system.

Listen to stereo sound in your link room

You can select stereo sound for programmes distributed from your main room sources, such as a set-top box, to the link room.

- > Press LIST on Beo4 until AV* is shown in the Beo4 display.
- > Press e.g. SAT to select a set-top box connected to the main room system, or DVD for a DVD player.

Please note that distribution of other main room sources to other link room systems in your home is not possible while AV is active!

The socket panel on the rear

The rear socket panel on BeoVision Avant allows you to connect signal input cables as well as a variety of extra equipment, such as a DVD player or a linked Bang & Olufsen audio system.

The AV and DECODER sockets are available for connection of extra equipment.

Any equipment you connect to these sockets must be registered in the BeoVision Avant *Connections* menu. Please refer to *Register extra equipment* on page 20 for more information.

Speaker and digital input socket panel

These sockets are only available if your BeoVision Avant has a built-in surround sound module!

REAR

The two sockets are used for connecting the external rear speakers in a surround sound setup.

FRONT

The two sockets are used for connecting the external front speakers in a surround sound setup.

SUBWOOFER

Socket used for connecting a BeoLab 2 subwoofer in a surround sound setup.

INPUT 1

Digital input socket (S/P DIF) for connection of e.g. a DVD player. INPUT 1 is for digital input from equipment connected to the AV socket on Avant.

INPUT 2

Digital input sockets (S/P DIF) for connection of e.g. a DVD player. INPUT 2 is for digital input from equipment connected to the DECODER socket on Avant.

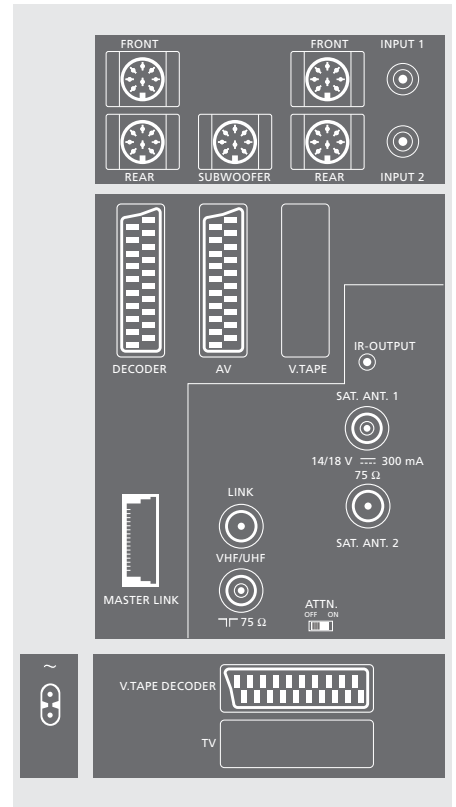

AV and aerial socket panel**DECODER**

21-pin socket for the connection of a secondary set-top box or a primary decoder. The socket provides the opportunity to connect either an AV decoder or an RF decoder.

The socket may be used for an AV 2 Expander instead, which gives the opportunity to connect a decoder, compact disc video player (CDV), and other non-Bang & Olufsen auxiliary video equipment at the same time.

AV

21-pin socket for the AV connection of other equipment, e.g. a second video recorder, a digital versatile video disc player (DVD), a set-top box*, a second decoder (neither MAC nor baseband decoders may be connected here).

The socket may also be used to connect a door camera (this requires a built-in Picture-In-Picture module). Contact your Bang & Olufsen retailer.

V. TAPE

21-pin socket for the connection of the built-in video recorder.

MASTER LINK

Socket for connection of a compatible Bang & Olufsen audio system.

The socket is also used for BeoLink distribution of sound and picture throughout the house. In addition, the socket can be used for an external positioner box (used in a satellite dish setup).

LINK

Aerial output socket for distribution of video signals to other rooms.

VHF/UHF

Aerial input socket from your external aerial or cable TV network.

SAT. ANT. 1

Aerial connection for the primary LNB (outdoor dish number one). If you have a motor-controlled dish, it must be connected to this socket.

SAT. ANT. 2

Aerial connection for a second LNB (outdoor dish number two).

ATTN. ON/OFF

Aerial signal attenuator. Options are:

OFF: Normal setting
ON: Signals damped

IR OUTPUT

For connection of a set-top box. (Only available when a Set-top Box Controller is built into your BeoVision Avant).

Other sockets

Connection to the mains.

V. TAPE DECODER

Socket for connection of a decoder used for recordings only, e.g. if you want to record one coded programme while watching another coded programme (this requires two identical decoders). Remember to set the item *Source* in the *V.Tape tuning* menu to *V.Tape decoder*. Please refer to *See a list of scheduled recordings* on page 42 for further instruction.

TV

21-pin socket for connection of the built-in video recorder.

*NOTE! If a Set-top Box Controller is built into your BeoVision Avant, you may connect the set-top box to either the AV or the DECODER socket. Which socket to choose depends on the other equipment you have connected.

The close-up operation and socket panels

The BeoVision Avant close-up operation panel is located on top of the television, behind the display bar.

You will find that the differentiated spacing between the buttons, as well as the different button shapes, makes them easy to find and use, even when you are standing in front of BeoVision Avant.

There is also a small, covered socket panel located just below the close-up operation panel. Here you can connect headphones and e.g. listen to a TV programme, or you can connect a CamCorder and watch your home movies on the Avant.

The close-up operation panel

- Switches the BeoVision Avant to standby.

PLAY TIMER

Switches on the BeoVision Avant timer function, which ensures that any timer play instruction you have programmed into the system will be executed with the BeoVision Avant picture screen and/or speakers cut in.

TV

The TV button enables you to switch on the TV, and to step through your TV channel numbers.

SAT

The SAT button enables you to switch on to satellite TV, and to step through your satellite TV channel numbers.

V.TAPE

Starts playback of a loaded tape. Press and hold V.TAPE for more than three seconds, and the video tape recorder switches off immediately, stopping any function in progress.

REWIND

Rewinds the tape in the video tape recorder quickly to the beginning.

EJECT

Unloads the videotape you have loaded into the video tape recorder.

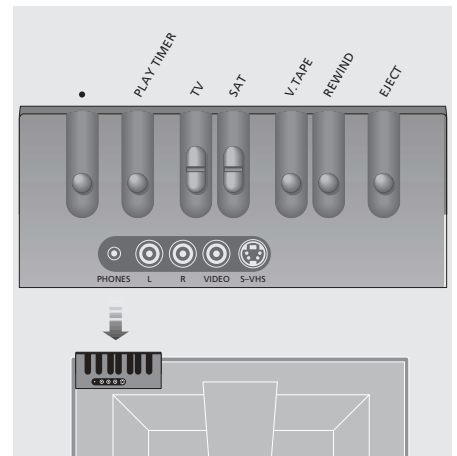

The L R and VIDEO sockets are hidden by a cover which you must remove before connecting a video camera.

The close-up socket panel

PHONES

You can connect stereo headphones to the socket marked PHONES. The BeoVision Avant speakers can then be cut out by pressing the Beo4 volume button in the middle.

L R VIDEO

The sockets marked L, R, and VIDEO are for connection of a video camera. L R sockets: For audio connection (left and right respectively). VIDEO socket: For the video signal.

S-VHS socket

For the connection of S-VHS or Hi-8 CamCorders only. To watch your CamCorder recordings on the BeoVision Avant, connect the camera and switch the BeoVision Avant on by pressing, e.g. the TV button on the Beo4 remote control. Then, when you start playback on your camera, the BeoVision Avant automatically registers the signal and you can see the pictures from the CamCorder on the screen.

If the signal from the CamCorder is switched off (accidentally), you must press LIST on Beo4 until CAMCORD is shown in the Beo4 display and press GO.*

Copy from a CamCorder to Avant

When you connect your CamCorder to the close-up sockets on the back of the BeoVision Avant display panel, you can copy your CamCorder recordings onto a videotape in the Avant. While the tape is being copied, you can watch a TV programme or switch off the TV entirely.

To copy a recording from a CamCorder

- RECORD** Connect your CamCorder to Avant and start playback of a CamCorder recording

- RECORD** Press to prepare Avant for recording

- Press again to start recording

- V TAPE STOP** Press V TAPE and then STOP to pause a recording

- RECORD** Press to resume a paused recording, or...

- TV** ...press a source button, such as TV, to stop a recording entirely

Connect a set-top box

If either the AV or DECODER socket is in use by e.g. a DVD player and you would like to connect two set-top boxes, you can connect the second set-top box to the close-up socket panel on the back of the Avant display bar.

**Even though you register a set-top box to your CamCorder sockets, you can still connect a CamCorder to the sockets on a temporary basis, without changing settings in the 'Connections' menu.*

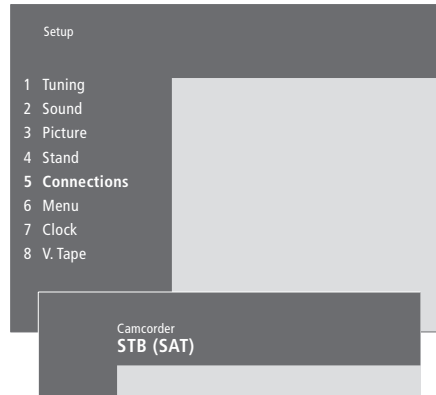

If you connect a set-top box to the CamCorder socket...

- > Switch on the system and press **MENU** to call up the main menu.
- > Press **4** to call up the *Setup* menu (5 if *Sat* is available).
- > Press **▼** to move the cursor down to *Connections*.
- > Press **MENU**. *Connections* changes to *CamCorder*.
- > Press **GO** to call up the *CamCorder* menu.
- > Press **▲** or **▼** to view your options. Select *STB(V.AUX)* if your BeoVision Avant is equipped with a built-in satellite receiver, and *STB(SAT)* if it does not. You can, of course, select *CamCorder* if you have connected a CamCorder to the close-up sockets. Press **GO**.
- > When you have registered your set-top box, you will be asked to select your set-top box type from an on-screen list. Please refer to page 21 for further information.
- > When you have selected your STB type, press **GO** to store the settings, or press **EXIT** to leave the menu.

You can gain access to a set-top box connected to the CamCorder socket in one of two ways. If your set-top box is registered as *STB(SAT)*, press **SAT** on Beo4. If it is registered as *STB(V.AUX)*, press **LIST** until *V.AUX** is shown, and then press **GO**.

*NOTE! In order for CAMCORD or V.AUX to be shown in the Beo4 display, they must first be added to the Beo4 list of functions. See *Activate extra functions via Beo4* on page 59 for further instruction.

The BeoVision Avant display bar

The BeoVision Avant display bar is located on top of the television. It informs you about the current status of your system.

The display bar informs you about the sources currently in use, about timed functions – such as a Timer recording of a TV programme – waiting to be executed, and about whether or not a recording is in progress. Certain sound types broadcast with TV or Satellite programmes will also be displayed, if they are present.



DIGITAL

Dolby Digital surround sound indicator.

PRO LOGIC

Dolby Pro Logic surround sound indicator.

Dolby Digital and Dolby Pro Logic Surround are only available in BeoVision Avant models equipped with a surround sound module. Please contact your Bang & Olufsen retailer for further information.

TIMER

Indicates that a timer recording has been programmed into the video tape recorder. *TIMER remains on during standby and blinks if a timer recording can not be executed.*

RECORD

'Recording in progress' indication for the video tape recorder.

PT (Play Timer)

Indicates that the BeoVision Avant Timer function for Timer playback or standby is switched on. Please refer to *Switch Avant on or off automatically* on page 50 for further information.

PT remains on during standby.

"TV 12" (Status display)

Status display for the BeoVision Avant. The display keeps you informed about what the system is doing or about an on-going operation.

• (Standby indicator)

The red standby indicator lights up when you switch off the BeoVision Avant. The system may still be active – for example, if a recording is in progress (RECORD will then be lit).

The standby indicator blinks to inform you that either a videotape is being rewound, or to inform you that you have left a videotape in the flap door. Please refer to *Load and play a videotape* on page 36.

The Beo4 buttons give access to direct remote control of a large number of functions in your BeoVision Avant. Yet the display on Beo4 enables you to operate even more functions.

Whenever a source is displayed on Beo4 (TV, RADIO, etc.), you can press the LIST button and call up extra functions in the display to help you operate that source, just as if you were calling up extra buttons. You can also switch on extra equipment connected to your BeoVision Avant.

A cue in the display only gives access to a function if that function is offered by your BeoVision Avant. You can, though, customise your Beo4 to suit your system with its added extras and also change the order in which these extra functions appear*.

When a new function is added to the Beo4 list, you will then be able to look up this new cue in the display the next time you operate your BeoVision Avant.



- Press and hold the standby button...

LIST ...then press LIST

Let go of both buttons

LIST Press until ADD is shown in the
ADD Beo4 display

GO Press to call up the list of
EDIT available cues. The first cue appears in the display

LIST Press until the desired cue is
TRACKNG shown

GO Press to add the cue to the list
ADDED *A cue is added to the list when ADDED is shown in the Beo4 display*

*NOTE! Please refer to Beo4's own User's guide for information about how to customise your extra functions.

Maintenance of your BeoVision Avant

Normal maintenance, such as cleaning the BeoVision Avant, is the responsibility of the user. To achieve the best result, follow the instructions included.

Any defective parts are covered during the warranty period. Please consult your Bang & Olufsen retailer to determine recommendations for normal maintenance.

Wipe dust off the surfaces using a dry, soft cloth. Remove grease stains or persistent dirt with a lint-free, firmly wrung cloth, dipped in a solution of water containing only a few drops of mild detergent, such as washing-up liquid.

About the contrast screen...

To clean the picture screen, use a *mild* window cleaning fluid to clean the screen. To retain the optimum performance of the screen, make sure that no streaks or traces of the cleaning fluid are left on the screen.

About the video tape recorder...

The video tape recorder has a built-in automatic head cleaning device. Videotapes designed to clean the video heads are therefore not required. However, further maintenance must be performed by a qualified technician only. Maintenance or malfunctions caused by incorrect maintenance are not covered by the international guarantee.

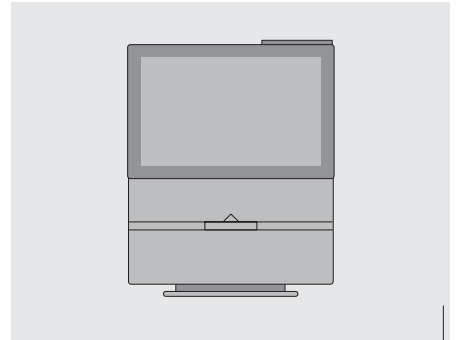

Never use alcohol or other solvents to clean any part of BeoVision Avant!

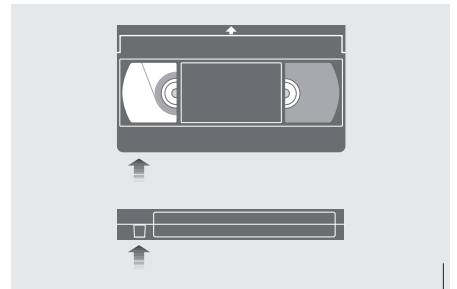

Videotapes should always be stored in a protective box at normal room temperature. Avoid extreme temperatures and humidity. You may protect your recordings from unintentional erasure by removing the latch on the rear edge of the cassette. Pry it off using a small screwdriver or other thin object. If, later on, you want to make a recording on such a protected tape, you can place a piece of tape over the recording lock.

*NOTE! If the front screen glass should crack or chip, or if it should be damaged in any way, it must be replaced immediately as it could otherwise cause bodily harm. You can order replacement front screen glass through your Bang & Olufsen retailer.

You can protect your BeoVision Avant by entering a four-digit PIN (Personal Identification Number) code. Should your Avant be disconnected from the mains for more than 30 minutes, only those who know your PIN-code can gain access to your BeoVision Avant system.

To activate the PIN-code system, to change your code or to delete it altogether, you must call up the PIN-code setup menu.

If you should lose or forget your code, contact your Bang & Olufsen retailer for a Master code that disables your PIN-code and gives you access to your BeoVision Avant system.

Activate the PIN-code system

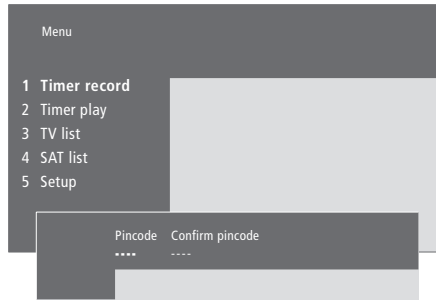

While the TV is on...

- MENU** Press to call up the main menu
- ◀ ◀** Press ◀ twice, followed by **STOP**. The Pincode menu appears on the screen
- 0 – 9** Use the number keys on Beo4 to enter the four digits of your code
- STOP** To cancel code entry, press STOP and the input fields are cleared
- ▶▶** When you have entered your code once, press ▶▶ to move the cursor to *Confirm pincode*
- 0 – 9** Re-enter the code a second time
- GO** When you have entered the correct code twice, press GO. The Avant display then shows the current source. If the two codes do not match, the input fields are cleared and you must enter the code again

Change or delete your PIN-code*

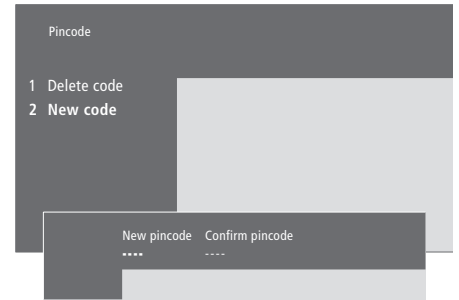

While the TV is on...

- MENU** Press to call up the main menu
- ◀ ◀** Press ◀ twice, followed by **STOP**. The BeoVision Avant display prompts you for your PIN-code
- 0 – 9** Use the number keys on Beo4 to enter your PIN-code
- STOP** To cancel code entry, press STOP and the input fields are cleared
- PIN** If the code does not match, the input fields are cleared and you must enter the code again
- 0 – 9** When you have entered your code, the *Pincode setup* menu prompts you to delete your code or enter a new code
- 1** Press 1 to delete your code, or **2** to enter a new code
- 0 – 9** To enter a new code, use the number keys on Beo4
- ▶▶** When you have entered your code once, press ▶▶ to move the cursor to *Confirm pincode* and re-enter the code
- GO** Press GO to store the new code

*NOTE! You can change your PIN-code up to five times in a three-hour period.

Use your PIN-code

Should your BeoVision Avant get disconnected from the mains for more than approximately 30 minutes, the Avant display prompts you for the correct PIN-code when the system is switched on.

When your system is switched on...

PIN _ _ _ _ _ Press the number keys on Beo4 to enter the code digits

0 – 9 If you enter an incorrect digit at any time, simply press STOP to reset the input fields

STOP

PIN _ _ _ _ _

PIN * * * * * Avant restarts when the last digit is entered

TV 1

ERROR If an incorrect code is entered, ERROR is shown in the display.

PIN _ _ _ _ _

PIN _ _ _ _ _

Re-enter the code

Five incorrect entries will cause the BeoVision Avant to shut down for three hours, during which remote control access is not possible.

Did you forget your PIN-code?

Contact a Bang & Olufsen retailer to receive a five-digit Master Code.

When you have received a Master Code...

Connect your system to the mains

◀◀ When BeoVision Avant prompts you for your PIN-code, press and hold **◀◀** to call up the MASTERCODE display

PIN _ _ _ _ _

0 – 9 Entering this five-digit code via the number keys will deactivate your PIN-code and reactivate BeoVision Avant. DELETED is shown in the Avant display

DELETED

For your information...

Your needs as a user are given careful consideration during the design and development process of a Bang & Olufsen product and we strive to make our products easy and comfortable to operate.

Therefore, we hope that you will take the time to tell us about your experiences with your Bang & Olufsen product. Anything which you consider important – positive or negative – may help us in our efforts to refine our products.

Thank you!

Write to: Bang & Olufsen a/s
Customer Service
Dept. 7210
Peter Bangsvej 15
DK-7600 Struer

or fax: Bang & Olufsen
Customer Service
+45 97 85 39 11 (fax)

or Email: beoinfo1@bang-olufsen.dk

Visit our Web-site on...
www.bang-olufsen.com

Manufactured under license from Dolby Laboratories. Confidential unpublished works. Copyright 1992-1997. All rights reserved.

DOLBY, DOLBY DIGITAL, PRO LOGIC and the double-D symbol are trademarks of Dolby Laboratories Licensing Corporation.



This product fulfils the conditions stated in the EEU directives 89/336 and 73/23.