

Guide



BeoCom 3 is well-suited for a home office or small business environment.

BeoCom 3 allows you to make and receive calls on two lines, as well as manage two concurrent calls on the same line. Combine as many as five calls into a single conference call.

BeoCom 3 has a built-in Phonebook to help you keep track of your personal and business numbers. It also supports the use of Caller ID and Call Waiting, if you have the appropriate subscription with your phone company.

BeoCom 3 also supports calls using a headset or hands-free calls – all with excellent sound quality.

You manage your calls using the built-in display. The display information guides you when you want to make a call, answer a call or adjust phone settings.

Contents

Connect your BeoCom 3

- 6 Placement and surroundings
 - Technical data
- 6 Connect BeoCom 3 to the phone line and the mains
- 6 Connect and use a headset

First-time setup of BeoCom 3

- 7 Enter clock and area code settings

Start using BeoCom 3

- 8 Keypad and display overview
 - What do the individual keys represent?
- 9 About the Extra key
- 9 Status indication
- 25 Overview of menus and extra functions

Daily use – make and answer calls

- 10 Make a call or answer a call
 - make, answer and end calls – switch between lines 1 and 2
- 10 Hands-free or headset calls
 - answer and make a call without lifting the handset; or with a connected headset
- 11 Edit a number while dialing
- 11 Turn the volume up or down during a call
- 11 Mute a call

The built-in Phonebook

- 12 Store name and number in the Phonebook after a call
 - Enter a name when the number is registered
- 12 Enter a new name and number in the Phonebook
- 13 Search the Phonebook to make a call
- 13 Search alphabetically in the Phonebook
 - Search from a first letter
- 13 Edit name and number in the Phonebook
- 14 Delete name and number in the Phonebook
- 14 Copy a name and number in the Phonebook

Extension number – call and store

- 15 Call an extension number
- 15 Store numbers with extensions in the Phonebook

Caller ID – use and editing

- 16 Using Caller ID
 - See names and numbers of incoming calls; make a call from a Caller ID entry
- 16 Delete calls from the Caller ID list – delete the entire list

Redial – use and editing

- 18 Using the Redial list
 - See names and numbers from outgoing calls, make a call from the Redial list
- 18 Delete names and numbers from the Redial list – delete the entire list
- 24 Store Redials from other phones

Switch between two calls

- 18 Calls on separate lines
 - Place a call on hold – resume a call
- 19 Calls on the same line – Call Waiting

Conference calls

- 20 A 2-line conference call
- 20 Three-way call – conference call on one line

For your information...

- 27 Contact Bang & Olufsen

Settings for your BeoCom 3

- 21 Volume, melody and settings for the ringing signal
 - Select the ringing signal volume, ringing signal melody and timed settings, i.e. when you would like the ringing signal to shut itself off automatically
- 22 Set the time and date
- 22 Preset volume for conversations
 - Choose the volume which suits you best
- 22 Display new calls

Advanced settings

- 23 Enter area code settings
- 23 Preset a flash time
- 24 Set the display contrast
- 24 Store calls from other phones
- 24 Preset a menu language

Overview of menu settings

- 25 Where to find a particular menu

Questions and answers

- 26 Does BeoCom 3 work during power outages?
- 26 Is the Phonebook, Caller ID list or Redial list deleted if the power fails or the phone line is disconnected?
- 26 Why do the indicator lights flash?
- 26 How do I undo a step or exit a function?
- 26 Why does the same number appear twice in the Caller ID list?
- 26 What happens if I reject an incoming call?

Connect your BeoCom 3

Place and connect the phone as described to the right. In case of a power failure, BeoCom 3 can be used for outgoing calls on line 1.

BeoCom 3 supports the use of a headset. You can switch between handset, headset, and hands-free use at any time.

Please note that BeoCom 3 can only be expected to function in country for which it was manufactured, as transmission systems, legal requirements for approval and supplementary services may vary from country to country. The packaging states the country for which your BeoCom 3 is manufactured. The national identity letters can be found above the bar code on the label.

If you require further instruction or information about the connection and use of BeoCom 3, please contact your Bang & Olufsen retailer.

Placement

BeoCom 3 should not be placed in damp, dusty or polluted surroundings and should not be directly exposed to liquids or sunlight.

BeoCom 3 is designed for use in dry, domestic environments only, with temperatures of 50–104°F (10–40°C) and relative humidity of 15–95%.

Connection

To be able to use your BeoCom 3, you must connect it to your telephone line (or lines) and to the mains.

- > If you have one phone line socket, connect the phone plug directly to this socket. If you have separate sockets for your phone lines, please refer to the illustration enclosed with the extra two-plug extension.
- > Connect the adapter to the mains.

Connect and use a headset

Connect a headset to the socket on the right side of the BeoCom 3 console.

Make a call using a headset

0 – 9 Enter the phone number

Headset Press to make a headset call

Headset Press to end your call

An optional headset can be purchased from your Bang & Olufsen retailer.

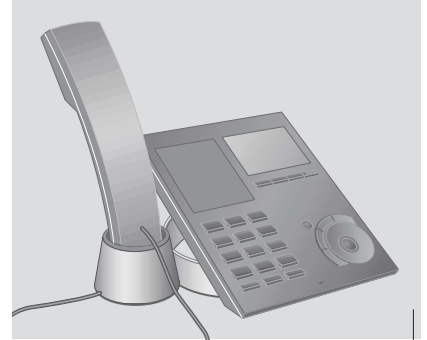

Please clean your BeoCom 3 using a soft, damp cloth with a few drops of mild detergent added.

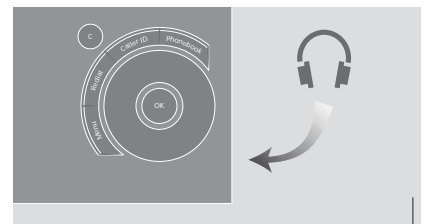
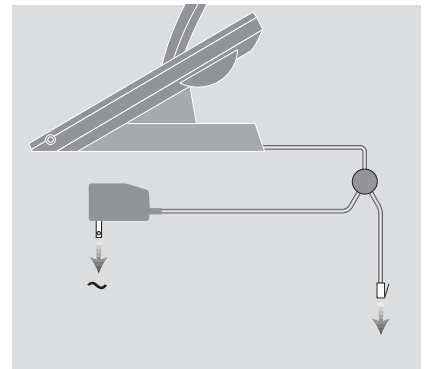

When you connect or disconnect a headset, 'Headset connected' or 'Headset disconnected' appears briefly in the BeoCom 3 display.

When you connect BeoCom 3 to your telephone line and to the mains, the display prompts you to enter settings for the built-in clock, as well as for the use of area codes.

The clock settings include time, date and year. Area code settings provide you with the option of including area codes when dialing locally, as well as the capacity to store up to ten area codes.

You only need to enter area code settings once. Clock settings must be re-entered if BeoCom 3 is disconnected from the mains temporarily.

Enter clock and area code settings

Settings for the built-in clock and for the use of area codes appear in the 'First time setup' menu. Both groups of settings can be adjusted at any time. Please refer to pages 22–23 for further information.

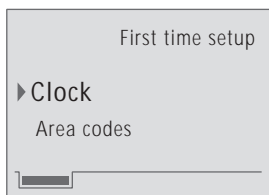

When you connect BeoCom 3 to the mains...
The 'First time setup' menu appears.

- Turn the wheel to select either 'Clock' or 'Area codes' settings
- OK** Press to be able to enter new settings
- Turn the wheel to select digits in e.g. the time or date
- OK** Press OK to move on to the next digit, or press **C** to go back to a previous digit
- 0 – 9** To enter area codes, press the digit keys
- OK** Press to store your entries

Options in the 'Area codes' menu

Your telephone company may or may not require you to dial an area code when making a local call. The area code requirements differ from company to company. Select the options listed below to match the requirements of your telephone company.

'Dial'... Options are *Yes* and *No*. Indicates whether or not area codes must be dialed for local calls.

'Area code'... Allows you to enter up to ten area codes.

If your phone company requires you to dial...

- 1+area code+number for all calls... set 'Dial' to *Yes* and do not enter an area code for the option 'Area code'.
- area code+number for local calls... set 'Dial' to *Yes*. For 'Area code', you can enter up to ten area codes that fall within your local calling area.
- neither 1 nor area code for local calls... set 'Dial' to *No* and enter your own area code for 'Area code'.

Start using BeoCom 3

Apart from fulfilling its function as an all-round phone, BeoCom 3 has many features.

In order to give you a quick overview of how to use BeoCom 3, the functions of the specific keys are described here. The display content is also explained, as are the indicator lights below the display.

For further information about menu options, please refer to page 25.



0 – 9

Digit keys for entering phone numbers.

*

Keys used in phone numbers, for supplementary services etc.

Mute

Mutes and reconnects the microphone during a call.

Speaker

Switches the hands-free function on and off – enables you to make and answer a call without lifting the handset.

Headset

Switches over to headset use.

Indicator lights

The indicator lights above Lines 1 or 2 light up when the lines are active, or flash to indicate the status of a line.

Line 1 Line 2

Select which line to use – line 1 or 2.

Extra*

Display additional functions in defined situations.

Flash

Switch from an active call to another call on the same line; make a call while another call is on hold on the same line.



Turn the wheel to search the Phonebook, the Caller ID and Redial lists or the phone's menu system; during a call, turn the wheel to adjust the volume up or down.

OK

Press OK to accept or store entries, as well as to confirm your choice of options shown in the display.

Phonebook

Open the Phonebook.

Caller ID

Show the Caller ID list in the display.

Redial

Show the Redial list in the display.

Menu

Show the phone's main menu in the display.

C (Clear)

Delete the most recent entry or cancel the last key pressed. Press and hold the C key to leave the menu system or an active function. C can also be used to mute the ringing signal for an incoming call.

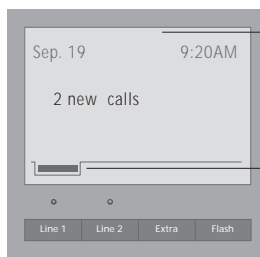

The phone display shows the current status of the phone and guides you through operations and functions.

The guide tab shown in the display indicates which line is in use, whether extra functions are available and whether a conference call is active.

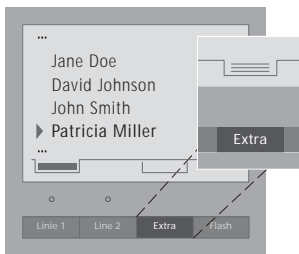

*About the Extra key...

In certain situations, you can gain access to additional functions. In these cases, a guide tab is visible in the display, just above the Extra key. Extra functions are available e.g. in the Phonebook, in the Caller ID and Redial lists, and in situations where you manage several calls at the same time.

While you e.g. enter a name in the Phonebook the Extra key allows you to:

- > enter a number.
- > insert national letters while you are typing a name – see page 12 for further information about national letters;
- > escape or avoid storing an entry.

Status indication

When the phone is not in use, the indicator lights above the keys Line 1 and 2 flash if...

- the phone rings. The indicator light flashes red;
- a call has been placed on hold. The indicator light flashes green;
- the ringing signal is disconnected – the phone still registers calls, but does not ring. The indicator light flashes red.

The indicator lights shine a steady green if...

- a line is in use by BeoCom 3. The lights shine a steady red if...
- a line is in use by another phone connected to the same line.

Daily use – make and answer calls

BeoCom 3 handles two phone lines. Before you make a call, you can choose which line to use – line 1 or 2.

You can make and answer calls using the handset, hands-free, or using an optional headset, which is available from your Bang & Olufsen retailer.

You can switch between these three modes at any time by pressing the speaker or headset button on the console, or by lifting the handset. The duration of an active call is shown in the display until the call is ended.

During your conversation, you can adjust the volume by means of the wheel. If you do not wish the person on the phone to overhear a conversation you are having with a person in the room, you can mute the call.

Make a call or answer a call

To make a call, enter the number and then lift the handset. The number is dialed when the handset is lifted. You can also lift the handset first. The number is then dialed as each digit is entered.

Making a call...

- Line 1** Press to choose an available
- Line 2** line
- 0 – 9** Enter the number
- Lift the handset to make the call
- Place the handset in the cup to end the call

Answering calls...

- Lift the handset to answer calls
- If you do not wish to receive a call...*
- C** ...press C to mute the ringer. If you change your mind and the caller has not hung up, you can answer the call by lifting the handset
- Place the handset back into the cup to end the call

Hands-free or headset calls

Make or answer a call without lifting the handset, or make and answer calls using a headset. See page 6 for further information about connecting a headset.

Make or answer a call hands-free...

- 0 – 9** Enter the number
- Speaker** Press to make the call
- Speaker** Press to end the call
- To answer calls hands-free...*
- Speaker** Press to answer without lifting the handset
- Speaker** Press to end the call

Make or answer a call with a headset...

- 0 – 9** Enter the number
- Headset** Press to make the call
- Headset** Press to end the call
- To answer calls with a headset...*
- Headset** Press to answer the call
- Headset** Press to end the call

To switch from handset to headset or handsfree use, press and hold the Headset or Speaker buttons on BeoCom 3 while you place the handset in the cup. To change from headset or hands-free to handset use, simply lift the handset.

Edit a number

If you key in a wrong digit while entering a number, you can delete one digit at a time or delete the entire number and start over.

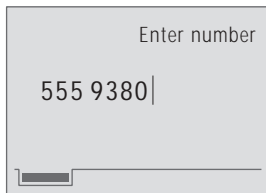

When entering a number...

-  Turn the wheel to highlight a digit you wish to delete
- C** Delete the digit
- C** Press and hold for approximately 2 seconds to delete the entire number
- 0 - 9** Edit the number or enter the whole number again

If you lift the handset first and then enter the number, it is not possible to edit the number.

Turn the volume up or down

During a call, you can adjust the volume in eight steps.

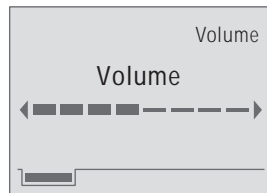

Turn the wheel to increase or decrease the volume during a call

You can preset the volume for all telephone conversations in the 'Setup' menu. Please refer to page 22 for further information.

Mute a call

Mute the microphone if e.g. you need to speak privately with someone in the same room while another person is on the line.



Mute Press once to turn off the microphone

Mute Press again to turn the microphone back on

When you mute the current call, the indicator light flashes green to remind you that the call is muted.

The built-in Phonebook

The built-in Phonebook will quickly become your personal reference when you call family or friends.

You can search the Phonebook in different ways. Search through all names or search alphabetically by the first letter in an entry. Naturally, you can also search through numbers that have no names attached to them.

Depending on the length of the entries, the Phonebook can contain approximately 200 names and numbers. The entries are shown in the display in alphabetical order.

You can easily add an entry to your Phonebook immediately after a call is ended.

Store a name and number after a call

After a call, you are prompted to store in the Phonebook the number and name of the person with whom you have spoken. Choose capital and lower-case letters, digits and special letters from the list in the display. An empty slot in the list indicates a space, and  is the symbol for storing.

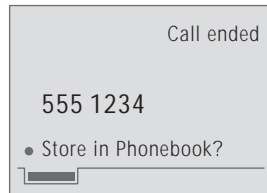



After a call...

OK Press to store the number and to be able to enter a name

 Turn the wheel to select the individual letters of the name

OK Press to store the chosen letter

Finish writing the name...

 Turn the wheel until  appears and press OK to store name and number

If you need a country-specific letter...

Extra Press the Extra key

 Turn the wheel to select 'National letter' and press OK

 Turn the wheel to select the desired letter and press OK

Enter a new name and number

When entering names and numbers, you can use up to 25 letters in a name and up to 48 digits in a number. There is one line for a name and one for a number. The number of available entries in the Phonebook is dependent upon the length of each entry; long entries limit this number.

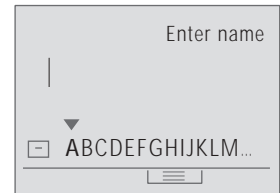

Menu Press to view the main menu



OK Press to open the Phonebook menu

OK Press to select 'Create new entry'

 Turn the wheel to select letters for the name

OK Press to store the chosen letter

Finish writing the name...

 Turn the wheel until  appears and press OK to store the name

0 - 9 Enter the number

OK Press to store the name and number

You can also enter the number first. When you press OK to store the number, you gain direct access to the naming function.

Search through all names in the Phonebook

When the phone is not in use, you can search directly from the entire list of names in the Phonebook. If you are making a call and wish to look for a number or a name in the Phonebook, press the Phonebook key first.



Search from first letter

To search through entries in the Phonebook by their first letter, start by selecting a letter. You can then view all names beginning with that letter. If you want access to the entire Phonebook, or to names beginning with another letter, press the Phonebook key again.

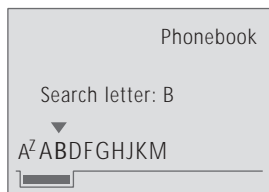

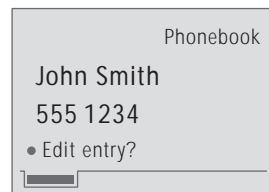

Edit a name or number

You can edit both names and numbers in the Phonebook using the 'Edit entry' menu.





When BeoCom 3 is not in use...







-  Turn the wheel to search the entire Phonebook
- OK** Press to select a name
-  Lift the handset to make the call

Search the Phonebook during a call...

- Phonebook** Press to open the Phonebook
- OK** Press to be able to search through all the names in the Phonebook
-  Turn the wheel to search through all names
- OK** Press to select a name

- Phonebook** Press to open the Phonebook menu
-  Turn the wheel to select a letter
- OK** Press to search through names which begin with the chosen first letter
-  Turn the wheel to search through the names
- OK** Press to select the name
-  Lift the handset to make the call



In the list of letters and digits at the bottom of the display, only the relevant first letters are shown – letters under which names are stored. If you wish to search through numbers that are not named, select ? from the list.

- Menu** Press to view the main menu
- OK** Press to open the Phonebook menu
-  Turn the wheel to select 'Edit entry' and press OK
- OK** Turn the wheel to select the first letter for the name and press OK
-  Turn the wheel to select a name and number and press OK
- OK** Press to be able to edit
- 0 – 9** Enter digits via the number keys. Press C to delete digits
- C**
- Extra** Press Extra to edit the name – use the wheel and the OK key to select 'Edit name'
-  **OK**
- C**
-  **OK** Press C to delete letters – use the wheel and the OK key to choose new letters for the name
-  **OK** *Finish editing the name...* Turn the wheel until  appears and press OK

Delete a name and number

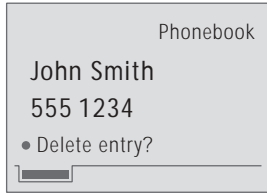
You can delete names and numbers in the Phonebook using the 'Delete entry' menu.







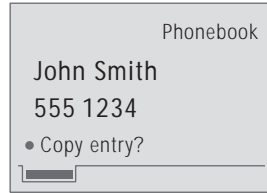

- | | |
|--|--|
| Menu | Press to view the main menu |
| OK | Press to open the Phonebook menu |
| 
OK | Turn the wheel to select 'Delete entry' and press OK |
| 
OK | Turn the wheel to select the first letter for the name and number and press OK |
| 
OK | Turn the wheel to select a name and number and press OK |
| OK | Press to delete a name and number |

Copy a name or number

If you have a number or a name which only needs slight alterations, copy the name and number and edit it.



- | | |
|--|---|
| Menu | Press to view the main menu |
| OK | Press to open the Phonebook menu |
| 
OK | Turn the wheel to select 'Copy entry' and press OK |
| 
OK | Turn the wheel to select the first letter for the name and number and press OK |
| 
OK | Turn the wheel to select a name and number and press OK |
| OK | Press to copy name and number |
| C

OK | Press C to delete letters – use the wheel and the OK key to choose new letters for the name |
| 
OK | Turn the wheel until  appears and press OK |

NOTE! If you have opened the Phonebook, the easiest way to edit, copy or delete an entry is to press the Extra key and select the appropriate function.

If you call a number with the intent of contacting an extension number, there is often a pause of a particular length before the call can be put through from the main switchboard to the extension number.

You can store the number, pause and extension in the BeoCom 3 Phonebook. You can then make future calls directly to the extension number.

You can choose a pause length between one and nine seconds. You can also choose a full-stop pause. In this case, the extension is entered when you press the OK button.

If you call an extension number manually, the main number, pause and extension are stored in the Redial list as a single entry. Please refer to *Redial – use and editing* for more information about the Redial list.

Call an extension number

If you call a number with an extension, you should await connection before entering the extension number. You can, however, insert a pause between the main number and the extension, and the complete number is stored in the Redial list for future use.

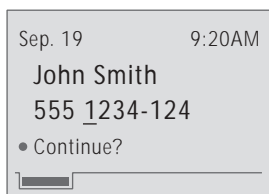



When dialing manually ...

- 0 – 9** Enter the main number
- Extra** Press to be able to insert a pause
-  Turn the wheel to select a pause length
- OK** Press to store the pause
- 0 – 9** Enter the extension number
- Lift the handset to make the call
- If you have set pause to 'Wait'...*
- OK** ...press to end a full-stop pause
- The complete number, including the pause and the extension, is now stored in the Redial list

Store numbers with extensions

Store the main number, the pause and the extension number as a single entry in the Phonebook. You can then call the number directly from the Phonebook.

Store in the Phonebook...

- 0 – 9** Enter the main number
- Insert a pause as described to the left
- 0 – 9** Enter the extension number
- OK** Press twice to store the entire number as well as the pause in the Phonebook
- OK**  Use the wheel and the OK key to assign a name to the number
- OK**  Turn the wheel until  appears and press OK

Call from the Phonebook...

- Phonebook** Press Phonebook
- OK**  Turn the wheel to select the number in the Phonebook and press OK
- Lift the handset to make the call
- OK** If you have set the pause length to *Wait*, press OK to send the extension number, otherwise, BeoCom 3 will send the extension number automatically when the preset amount of time has passed

Caller ID – use and editing

The latest 24 phone numbers you have received calls from are stored in the Caller ID list. Numbers are only stored once in the list, even if you have received several calls from the same number.

The display shows how many unanswered calls you have received.

If you bring up the Caller ID list in the display, you will find information about which line took the call, who called, the number of calls received and the time the last call was received. You can then make a call directly from the Caller ID list.

Using Caller ID



When you view the Caller ID list, the most recent call appears at the top of the list. While the list is shown in the display, you have access to Extra functions which allow you to e.g. delete Caller ID calls, edit a name and number, and store an entry in the Phonebook.

Make a call from the Caller ID list...

- | | |
|---|---|
| Caller ID | Press to view the Caller ID list |
|  | Turn the wheel to select name and number |
| OK | If you wish to access Caller ID information, press OK, otherwise...

...lift the handset to make the call |



Store a Caller ID in the Phonebook...

- | | |
|---|--|
| Caller ID | Press to view the Caller ID list |
|  | Turn the wheel to select name and number |
| Ekstra | Press to gain access to additional functions |
|  | Turn the wheel to select 'Store in Phonebook' and press OK |



Delete calls in the Caller ID list

When you bring up the Caller ID list in the display, you can then delete a specific call or the entire list directly.

Delete a specific Caller ID call...

- | | |
|--|---|
| Caller ID | Press to view the Caller ID list |
|  | Turn the wheel to select name and number and press OK |
| Extra | Press to gain access to additional functions |
|  | Turn the wheel to select 'Delete entry?' |
| OK | Press to delete the selected Caller ID call |

To delete the entire list...

- | | |
|--|--|
| Caller ID | Press to view the Caller ID list |
| Extra | Press Extra and turn the wheel to select 'Delete the list?' and press OK |
|  | |
|  | Turn the wheel until 'Yes' is highlighted |
| OK | Press to delete the entire list |

NOTE! If Caller ID information is not available, the display shows:

'Private call' – for calls from anonymous numbers;
'Unavailable' – when Caller ID is not possible for technical reasons.

You must have a subscription to Caller ID for the function to be available.

The 24 phone numbers you have called most recently are stored in the Redial list. Numbers are only stored once in the list, even if several calls have been made to one number.

When the Redial list is brought up in the display, you will find information about which line the last call was made from, who the last call was made to, the duration of the call and when the call was made. You can then make a call directly from the Redial list.

For information about storing Redials from another phone, please refer to *Advanced settings*.



Using the Redial list

When the Redial list is shown in the display, your latest call appears at the top of the list. While the list is shown, you have access to Extra functions. You can delete a Redial entry, edit a name and number and store an entry in the Phonebook.

To make a call from the Redial list...

- Redial** Press to view the Redial list
-  Turn the wheel to select name and number
- OK** If you wish to gain access to Redial information, press OK, otherwise...
...lift the handset to make the call



Store Redials in the Phonebook...

- Redial** Press to view the Redial list
-  Turn the wheel to select name and number
- Extra** Press to gain access to additional functions
-  Turn the wheel to select 'Store in Phonebook' and press
- OK** OK

Delete calls in the Redial list

While the Redial list is shown in the display, you can delete a specific Redial entry or the entire list.

Delete a specific Redial entry...

- Redial** Press to view the Redial list
-  Turn the wheel to select name and number and press OK
- Extra** Press to access additional functions
-  Turn the wheel to select 'Delete entry?'
- OK** Press to delete the selected Redial entry

To delete the entire list...

- Redial** Press to view the Redial list
- Extra** Press Extra, turn the wheel to select 'Delete the list?' and press OK
-  Turn the wheel until 'Yes' is highlighted
- OK** Press to delete the entire list

Switch between 2 calls

BeoCom 3 makes it possible for you to handle simultaneous calls, whether the calls are on separate lines or on the same line.

Use the line keys to switch back and forth between calls on the two lines. The indicator lights show the status of both lines.

There is no need to press a separate 'Hold' button, as switching from one line to another automatically places the non-active call on hold.

If, for example, you have an active call on line 1, and you receive an incoming call on the same line, you can place the first call on hold and answer the new call. Please note, however, that placing a call on hold in this manner requires that you have a subscription to the basic Call Waiting service with your phone company.

Calls on separate lines

You switch between calls on lines 1 and 2 by pressing the Line 1 or Line 2 keys. The guide tabs in the display and the indicator lights show which line is active and whether or not a call on the other line is placed on hold.

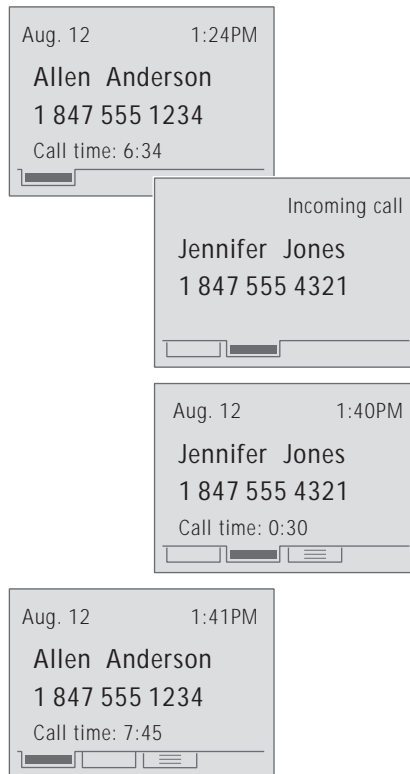

You have an active call on line 1 and an incoming call on line 2...

The indicator light for line 1 shines steadily green to show that the line is active, and the indicator light for line 2 flashes red to indicate an incoming, unanswered call.

> Press **Line 2** to answer the incoming call on line 2. The duration of the new call is shown in the display. The indicator light for line 1 flashes green to indicate a call on hold, and the indicator light for line 2 shines a steady green to indicate an active call.

> Press **Line 1** to return to line 1. Line 2 is then on hold.

> If, instead, you wish to end the call on line 1 before answering the incoming call on line 2, press the cup once, and then press **Line 2** to return to the call on line 2.

If you are using BeoCom 3 hands-free or with a headset, you can also press 'Speaker' or 'Headset' respectively to end one call before selecting the call on the other line.

Calls on the same line - Call Waiting

Use the Flash button to place a call on hold while you answer an incoming call, or to switch between two calls.

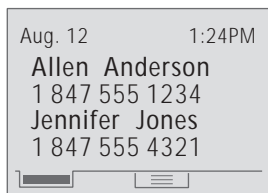

You have an active call and an incoming call is registered on the same line...

The number and name of the incoming call appear in the display.

- > Press OK or the Flash button to place the active call on hold and answer the incoming call.
- > Press the Flash button to switch back and forth between the two calls.

You can also end the active call and answer an incoming call on the same line by pressing and holding the handset cup for a couple of seconds. The active call is then ended and the incoming call becomes active.

Conference calls

BeoCom 3 makes it possible for you to include multiple calls in a conference call.

You can combine calls on line 1 and line 2 to a conference call, and you can combine calls on the same line to a conference call as well. However, to combine calls on the same line, you must have a subscription to your phone company's Three-Way Call service for that line.

A three-way call on one line can be combined with a single active call on the other line for a fourway conference call. Three-way calls on both line 1 and line 2 can also be combined to a five-way conference call.

If you choose to make a three-way call part of a larger conference call, please note that you must initiate all the calls in the three-way call.

A 2-line conference call

When you have simultaneous calls on both line 1 and line 2, you can connect the calls and establish a conference call.

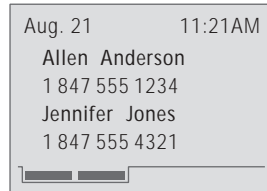

You have simultaneous calls on both lines...

- | | |
|--------------|---|
| Extra | Press to be able to connect the calls |
| OK | Press to include the selected calls in a conference |
- Place the handset in the cup to end all calls, or press the line buttons to return callers to separate lines. You can then continue or end calls as you choose

You can also create a conference call by pressing the Line 1 and Line 2 buttons simultaneously. All parties on both lines are then included in the conference call.

Please note that external parties in a conference call will hear each other only faintly if they are located far from the telephone exchange. This network problem can be reduced by subscribing to the Three-Way Call service with your telephone company.

Three-way call – conference call on one line

When you establish a three-way call, the first call made can be an incoming or outgoing call, but you must initiate the second call yourself. Please contact your phone company for more information about the Three-Way Call service.

You have a call on e.g. Line 1...

- > Press the Flash button to place the active call on hold and start a new call.
- > Place a call to the third party in your three-way call.
- > When the third party answers the call, press Flash again to start a conference call.
- > To end the conference call, press Flash a third time. The third party is disconnected and you can continue the original call.
- > Place the phone in the cup to end the call completely.

In the BeoCom 3 'Setup' menu, you can:

- preset the ringing signal volume, choose a ringing signal melody and preset the ringing signal to shut itself off automatically e.g. at night;
- set the time, date and year for the built-in clock;
- preset a fixed volume for your phone conversations;
- choose whether or not to show Caller ID status in the display.

Volume, melody and ringing signal settings

When you set the ringing signal, you can adjust the volume, choose between 8 melodies and preset the ringing signal to shut off automatically e.g. between 10 pm and 8 am.

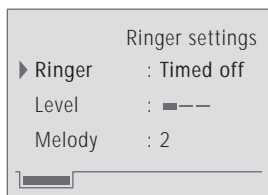

Setup options for the ringing signal

If you switch off the ringing signal, BeoCom 3 will not ring. However, incoming calls are still registered in the Caller ID list.

Ringer

Select settings *On*, *Off*, or *Timed Off*. Choose *Timed Off* to silence the ringing signal in a fixed period of time, e.g. between 10 pm and 8 am.

Level

Only available if Ringer is set to *On* or *Timed Off*. Select a volume level for the ringing signal. Options are *Low*, *Medium* and *High*.

Melody

Only available if Ringer is set to *On* or *Timed Off*. Select ringing signal melody 1–8.





If you wait 3 seconds after selecting the setting for the volume or melody of the ringing signal, the chosen ringing signal is then played.

- | | |
|----------------|--|
| Menu | Press to view the main menu |
| ○
OK | Turn the wheel to select 'Setup menu' and press OK |
| ○
OK | Turn the wheel to select 'Ringer' and press OK |
| ○
OK | Turn the wheel to choose line 1 or line 2 and press OK |
| ○
OK | Turn the wheel to select options on the menu and press OK |
| ○ | Turn the wheel to preset ringing signal volume or choose a ringing signal melody |
| OK | Press to store your settings |

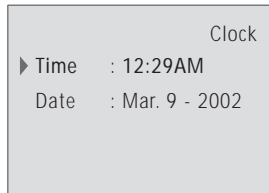
Set the time and date

The built-in clock ensures that timer settings for the ringing signal are executed correctly, and that Caller ID information includes the correct date and time of the call.





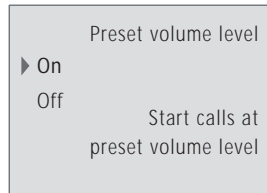

- | | |
|---|---|
| Menu | Press to view the main menu |
|  | Turn the wheel to select 'Setup menu' and press OK |
| OK | |
|  | Turn the wheel to select 'Clock' and press OK |
| OK | |
|  | Turn the wheel to select either 'Time' or 'Date' and press OK |
| OK | |
|  | Turn the wheel to select the individual settings, and press OK to move on to the next |
| OK | |
| | When you have entered the last setting, 'Store?' appears in the display |
| OK | Press to store the setting |

Preset volume for conversations

The sound volume can be set to one of eight fixed levels. This volume then applies to the handset, the speaker and any connected headset. Note that you can still adjust sound volume during a call.





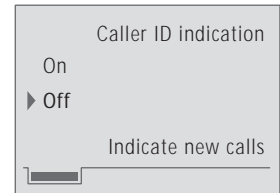

- | | |
|---|---|
| Menu | Press to view the main menu |
|  | Turn the wheel to select 'Setup menu' and press OK |
| OK | |
|  | Turn the wheel to select 'Preset volume' and press OK |
| OK | |
|  | Turn the wheel to select 'Yes' if you wish a preset volume, or 'No' if you do not |
| OK | |
|  | Press OK |
| OK | |
|  | If you chose 'Yes', turn the wheel to adjust the volume setting |
| OK | |
| OK | Press to store the setting |

Display new calls

You can choose not to display information about new calls, if e.g. you have a phone with Caller ID connected to the same line as BeoCom 3.



- | | |
|--|--|
| Menu | Press to view the main menu |
|  | Turn the wheel to select 'Setup menu' and press OK |
| OK | |
|  | Turn the wheel to select 'Caller ID indication' and press OK |
| OK | |
|  | Turn the wheel to choose line 1 or line 2 and press OK |
| OK | |
|  | Turn the wheel to select 'On' if you wish to see new calls, or 'Off' if you do not |
| OK | |
| OK | Press OK |
| | Repeat the procedure for each line |

BeoCom 3 has additional, 'advanced' settings, apart from those available in the 'Setup' menu.



These settings allow you to:

- enter the area codes which fall within your local calling area;
- adjust the time it takes to execute a 'flash' between calls on the same line;
- preset the display contrast for optimum viewing of display information;
- choose to store calls from other, connected phones in the BeoCom 3 Redial list;
- choose a menu language;

Enter area code settings

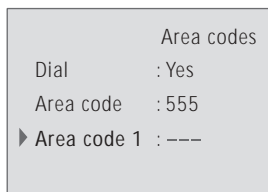
Settings for the use of area codes are entered during first-time setup of BeoCom 3, but can be adjusted at any time from the *Advanced settings* menu. Please refer to *First-time setup of BeoCom 3* for more information about the 'Area codes' menu.





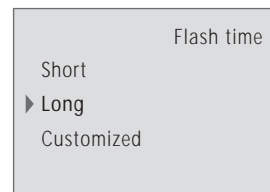

- | | |
|--|--|
| Menu | Press to view the main menu |
| 
OK | Turn the wheel to select 'Setup menu' and press OK |
| 
OK | Turn the wheel to select 'Advanced menu' and press OK. 'Area codes' is already highlighted |
| OK | Press OK |
| 
OK | Turn the wheel to select either 'Dial' or 'Area code' and press OK |
| 0 - 9 | Press the digit keys to enter area codes |
| C | Press C to go back to a previous digit, or... |
| OK | ...press OK to store your entries |

Preset a flash time

The requirements telephone companies have for the duration of a 'flash' – a switch to another call on the same line – may differ. You can preset a flash time.



- | | |
|---|--|
| Menu | Press to view the main menu |
| 
OK | Turn the wheel to select 'Setup menu' and press OK |
| 
OK | Turn the wheel to select 'Advanced menu' and press OK |
| 
OK | Turn the wheel to select 'Flash time' and press OK |
| 
OK | Turn the wheel to select short, long or customized flash time (in milliseconds) and press OK |
| 
OK | If you choose a customized flash time, turn the wheel to adjust the flash time and press OK to store the setting |

In most cases, it will be unnecessary to adjust flash time, as flash times should either match the 'short' or 'long' settings. If you experience problems with the flash function, please contact your telephone company for the precise flash time.

Set the display contrast

You can set the contrast of the phone display so that it suits you the best. There are five possible settings.

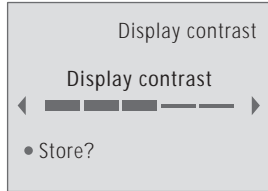

- | | |
|-------------|--|
| Menu | Press to view the main menu |
| | Turn the wheel to select 'Setup menu' and press OK |
| OK | |
| | Turn the wheel to select 'Advanced menu' and press OK |
| OK | |
| | Turn the wheel to select 'Display contrast' and press OK |
| OK | |
| | Turn the wheel to select the contrast |
| OK | Press to store the setting |

Store calls from other phones

You can choose whether BeoCom 3 should store calls from other phones – connected to the same line – in its Redial list. Switch 'Extended Redial' on or off.

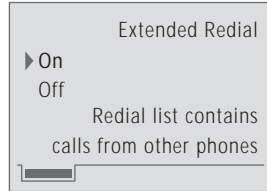

- | | |
|-------------|---|
| Menu | Press to view the main menu |
| | Turn the wheel to select 'Setup menu' and press OK |
| OK | |
| | Turn the wheel to select 'Advanced menu' and press OK |
| OK | |
| | Turn the wheel to select 'Extended Redial' and press OK |
| OK | |
| | Turn the wheel to select line 1 or line 2 and press OK |
| OK | |
| | Turn the wheel to select 'On' or 'Off' and press OK |
| OK | |

Repeat the procedure for each line

Preset a menu language

You can select a language for display messages. Choose between English, French and Spanish.

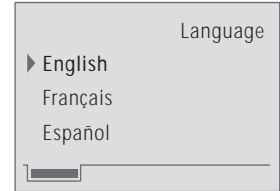

- | | |
|-------------|---|
| Menu | Press to view the main menu |
| | Turn the wheel to select 'Setup menu' and press OK |
| OK | |
| | Turn the wheel to select 'Advanced menu' and press OK |
| OK | |
| | Turn the wheel to select 'Language' and press OK |
| OK | |
| | Turn the wheel to select a menu language and press OK |
| OK | |

This chapter helps you to manoeuvre through the menus shown in the display.

Detailed information concerning the individual menus is located in the relevant chapters of the guide.

Not all menus are shown in this illustration, but all main items of the menus are shown. Follow the instructions in the display to navigate through your options and settings.

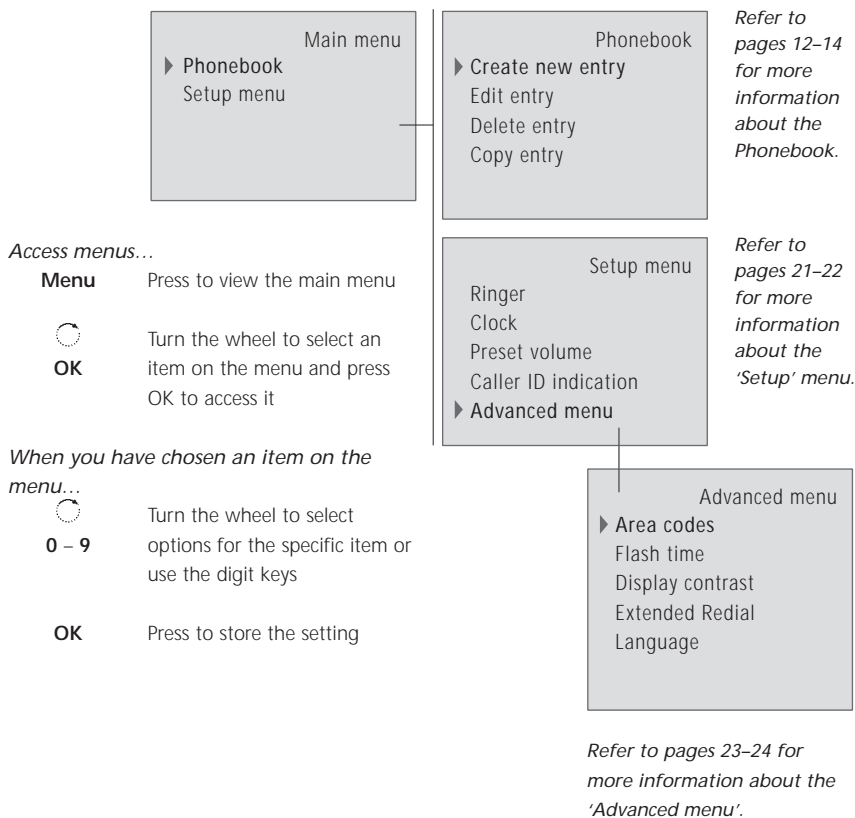

Questions and answers

Does BeoCom 3 work during power outages?

In case of a power failure, BeoCom 3 can be used for emergency outgoing calls – albeit with reduced functionality. The lights in the display are off, and the guide tabs are non-functional. Only the number keys, * and # function normally. All calls made during a power failure are made via Line 1. To make a call, pick up the handset and dial the number manually.

Is the Phonebook, Caller ID list or Redial list deleted if the power fails, or if the telephone line is disconnected?

No. The Phonebook, the Caller ID list, and the Redial list remain intact and fully functional in both situations.

Why do the indicator lights flash?

The indicator lights above the buttons for Line 1 and Line 2 flash green to indicate that there is a call on hold on the relevant line, and flash red to indicate an incoming call on the relevant line.

How do I undo a step if, for example, I press the wrong button? Can I exit a function?

Press the C button (for 'Clear') to undo the last button pressed, or to exit a menu or function.

Why does the same number appear twice in the Caller ID list?

You have received calls from the same number on both Line 1 and Line 2.

I have Call Waiting. What happens if I reject an incoming call?

If you reject an incoming call (by pressing C), the caller will hear a ringing signal, as though the call has not been answered.

Your needs as a user are given careful consideration during the design and development process of a Bang & Olufsen product and we strive to make our products easy and comfortable to operate.

Therefore, we hope that you will take the time to tell us about your experiences with your Bang & Olufsen product. Anything which you consider important – positive or negative – may help us in our efforts to refine our products.

Thank you!

Write to: Bang & Olufsen a/s
Customer Service
Peter Bangs Vej 15
DK-7600 Struer

or fax: Bang & Olufsen
Customer Service
+45 97 85 39 11 (fax)

or e-mail: beoinfo1@bang-olufsen.dk

Visit our Web-site on:
www.bang-olufsen.com

For the Canadian market only...

NOTICE: The Industry Canada label identifies certified equipment. This certification means that the equipment meets telecommunications network protective, operational and safety requirements as prescribed in the appropriate Terminal Equipment Technical Requirements document(s). The Department does not guarantee the equipment will operate to the user's satisfaction.

Before installing this equipment, users should ensure that it is permissible to be connected to the facilities of the local telecommunications company. The equipment must also be installed using an acceptable method of connection. The customer should be aware that compliance with the above conditions may not prevent degradation of service in some situations. Repairs to certified equipment should be coordinated by a representative designated by the supplier. Any repairs or alterations made by the user to this equipment, or equipment malfunctions, may give the telecommunications company cause to request the user to disconnect the equipment.

Users should ensure for their own protection that the electrical ground connections of the power utility, telephone lines and internal metallic water pipe system, if present, are connected together. This precaution may be particularly important in rural areas.

CAUTION: Users should not attempt to make such connections themselves, but should contact the appropriate electric inspection authority, or electrician, as appropriate.

NOTICE: The Ringer Equivalence Number (REN) assigned to each terminal device provides an indication of the maximum number of terminals allowed to be connected to a telephone interface. The termination on an interface may consist of any combination of devices subject only to the requirement that the sum of the Ringer Equivalence Numbers of all the devices does not exceed 5.

For the American market only...

This equipment complies with Part 68 of the Federal Communications Commission (FCC) rules for the United States.

A label is located on the underside of the base unit containing either the FCC registration number and Ringer Equivalence Number (REN). You must upon request, provide the following information to your local telephone company:
USOC Jack Type: RJ 11
REN: 0.4B

Should you experience trouble with this telephone equipment, please contact:

Bang & Olufsen America, Inc.
780 West Dundee Road
Arlington Heights, IL 60004
U.S.A.
Phone: (847) 590-4900
Main Fax: (847) 255-7805

The REN is used to determine the quantity of devices which may be connected to the telephone line. Excessive RENs on the telephone line may result in the devices not ringing in response to an incoming call. In most, but not all areas, the sum of RENs should not exceed five (5.0). To be certain of the number of devices that may be connected to a line, as determined by the total RENs, contact the local telephone company.

If trouble is experienced with BeoCom 3, for repair or warranty information, please contact:

Bang & Olufsen America, Inc.
780 West Dundee Road
Arlington Heights, IL 60004
U.S.A.
Phone: (847) 590-4900
Main Fax: (847) 255-7805

If the equipment is causing harm to the telephone network, the telephone company may request that you disconnect the equipment until the problem is resolved.

This equipment cannot be used on public coin phone service provided by the telephone company. Connection to party line service is subject to state tariffs.

Your telephone company may discontinue your service if your equipment causes harm to the telephone network. They will notify you in advance of disconnection, if possible. During notification, you will be informed of your right to file a complaint to the FCC.

Occasionally, your telephone company may make changes in its facilities, equipment, operation, or procedures that could affect the operation of your equipment. If so, you will be given advance notice of the change to give you an opportunity to maintain uninterrupted service.

