

# BeoLab 9

## Guide

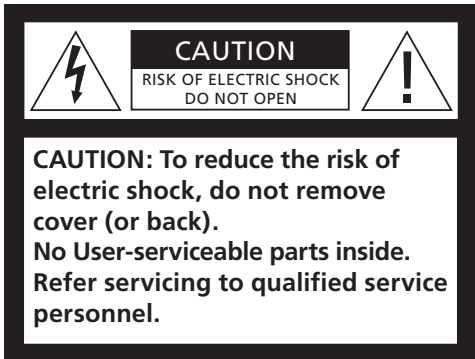

**WARNING:** To reduce the risk of fire or electric shock, do not expose this appliance to rain or moisture. Do not expose this equipment to dripping or splashing and ensure that no objects filled with liquids, such as vases, are placed on the equipment.

To completely disconnect this equipment from the AC Mains, disconnect the power supply cord plug from the AC receptacle.



The lightning flash with arrowhead symbol within an equilateral triangle, is intended to alert the user to the presence of uninsulated “dangerous voltage” within the product’s enclosure that may be of sufficient magnitude to constitute a risk of electric shock to persons.



The exclamation point within an equilateral triangle is intended to alert the user to the presence of important operating and maintenance (servicing) instructions in the literature accompanying the product.

This Guide describes how to set up a pair of loudspeakers and prepare them for use. The Guide provides useful information when you set up the loudspeakers for the first time, and later, if you have to move or rearrange your setup.

Follow the instructions in this Guide carefully.

## **Daily use, 4**

Information about how to use the loudspeakers, about the built-in protection system, and how to clean the loudspeakers.

## **Set up the loudspeakers, 5**

Important information to consider before setting up the loudspeakers.

## **Cable connections, 6**

Information about the sockets, switches, cables, and how to connect the loudspeakers to your system.

## **Adapt your loudspeakers to your room, 8**

Find out about the POSITION switch, and how to set it in order to adapt each loudspeaker to its surroundings (bass alignment).

## Daily use

When you have finished setting up the loudspeakers as described on the following pages, connect the entire system to the mains supply. The indicators light up in red, indicating that the loudspeakers are in standby, ready to be used.

The loudspeakers are designed to be left in standby mode when not in use.

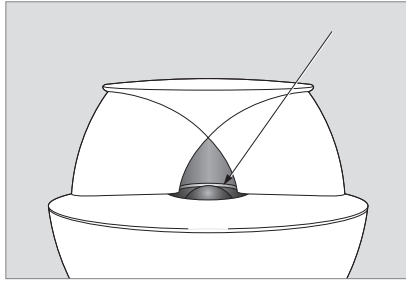

*The indicator light is positioned behind the exposed speaker membrane in the acoustic lens.*

### Switching on and off

When you switch on your system, the loudspeakers switch on simultaneously, and the indicator lights turn green. When you switch the system off again the loudspeakers also switch to standby.

### Cleaning the loudspeaker

Clean dusty surfaces using a dry, soft cloth. If necessary, remove grease stains or persistent dirt with a soft, lint-free cloth which you have dipped in lukewarm water and wrung firmly.

Never use a vacuum cleaner to clean the exposed speaker membrane in the acoustic lens. However, the front cloth may be cleaned with a vacuum cleaner with a brush nozzle, and set to the lowest level.

*Never use alcohol or other solvents to clean any parts of the loudspeaker!*

### Loudspeaker protection

Each loudspeaker is equipped with a thermal protection system which prevents damage from overheating. If an error occurs – or the speaker units become overheated – the system automatically switches the loudspeaker to standby, and the indicator light turns yellow.

### To restore the sound:

- > Disconnect the loudspeaker from the mains supply.
- > Allow the system time to reset or cool down (approximately 3–5 minutes).
- > Reconnect the loudspeaker to the mains supply.

*Should the problem persist, contact your Bang & Olufsen retailer.*

We recommend that you follow this procedure when you set up the loudspeakers:

- Disconnect your system from the mains supply.
- Connect your loudspeakers and set the switch marked LINE–RIGHT–LEFT on each loudspeaker as explained in 'Cable connections' (pp. 6–7).
- Set the switch marked FREE–WALL–CORNER to the correct setting on each loudspeaker. This is explained in 'Adapt the loudspeakers to your room' (pp. 8–9).
- Connect your entire system to the mains supply again.

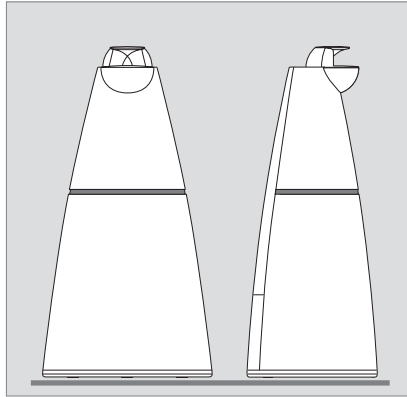

*The loudspeakers must be placed standing upright on the base on a firm and level surface.*

## Cautions

- Make sure that the loudspeakers are placed and connected in accordance with the instructions in this Guide. To prevent injury, use Bang & Olufsen approved stands and wall brackets only!
- The loudspeakers can only be switched off completely by disconnecting them from the mains supply. Therefore, connect the loudspeakers to an easily accessible wall socket.
- Do not attempt to open the loudspeakers. Leave such operations to qualified service personnel!
- The loudspeakers are designed for indoor use in dry, domestic environments only, and for use within a temperature range of 10–40° C (50–105° F).
- For optimum sound quality, do not place the loudspeakers enclosed in a small space, and never place anything directly in front of the loudspeakers.
- Place the loudspeakers with the front facing your favourite listening position.

## Cable connections

The loudspeakers can be used with Bang & Olufsen audio, video and link systems. They may also be connected to non-Bang & Olufsen systems.

For specific information about the sockets on your system, refer to the Guide enclosed with the system.

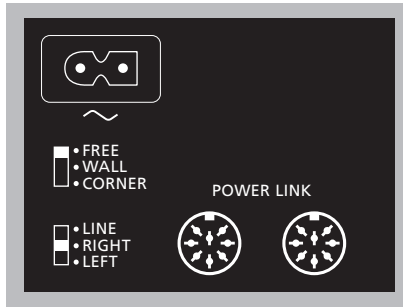

The sockets and the two switches are located on the rear of the loudspeaker. Remove the cover to get access to the sockets and switches.

### Connection panel

#### FREE–WALL–CORNER switch

This switch has three settings. Which setting to use depends on the placement of the loudspeakers. This is explained in 'Adapt the loudspeakers to your room' (pp. 8–9).

#### LINE–RIGHT–LEFT switch

This switch has three settings. Set the switch to RIGHT or LEFT, when connecting the loudspeakers to a Bang & Olufsen system. Set the switch to LINE when connecting the loudspeakers to a non-Bang & Olufsen system.

#### POWER LINK sockets

These sockets are used for connection to a Bang & Olufsen system. However, if the switch marked LINE–RIGHT–LEFT is set to LINE, you may use one of the Power Link sockets to connect the loudspeaker to a non-Bang & Olufsen system.

~

Socket for connection to the mains supply.

### Connection to Bang & Olufsen systems

Use the enclosed Power Link cables to connect the loudspeakers to your system.

Set the LINE–RIGHT–LEFT switch to RIGHT and LEFT (the right and left sound channel), respectively.

### Connection to non-Bang & Olufsen systems

Use a special adapter with an ordinary phono/RCA plug in one end, and a DIN-plug in the other ('Cable for line signal' – optional accessory, available from your Bang & Olufsen retailer).

Set the LINE–RIGHT–LEFT switch to LINE.

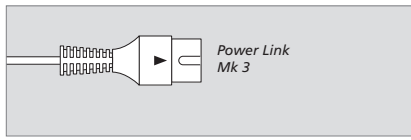
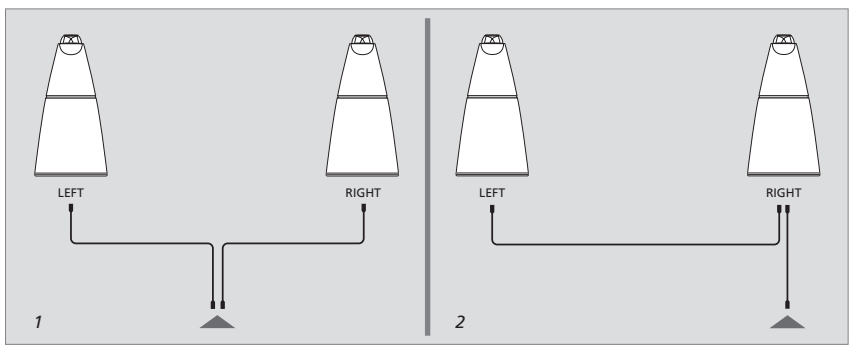

**Power Link cables:** The cables must be of the type which are marked with a triangle on the plug. Do not use any of the old type of Power Link cables, as this will cause noise, and thus not give optimum sound quality!

**Power Link connections:** These connections carry both the right and left sound signals. Therefore, you can:

- 1 Run a Power Link cable from your Bang & Olufsen system directly to each loudspeaker.
- Or
- 2 Run a Power Link cable from your Bang & Olufsen system to the first loudspeaker, and then run another Power Link cable to the next loudspeaker. This will often help to minimise cable clutter.

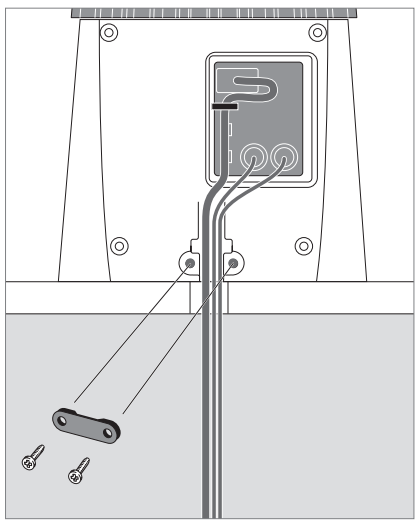

**Securing the cables:** For safety reasons, the mains lead must be fastened to the loudspeaker. To do so, tug the mains lead behind the small bracket on the connection panel. Then run all cables behind the clamp, and tighten the two screws.

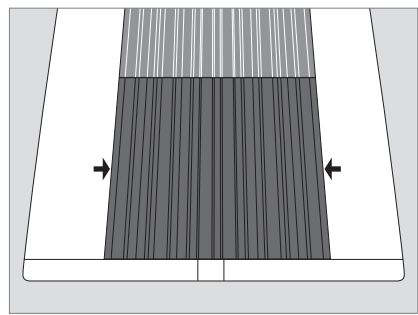

**Cover for the connection panel:** To remove the cover, grip it along the left and right edges – as indicated by the two arrows.

When you have made all the connections and secured the cables, fasten the cover again by inserting the four pegs on the rear of the cover into the corresponding holes on the loudspeaker.

## Adapt the loudspeakers to your room

The loudspeakers may be placed almost anywhere in your room. However, the most natural sound is obtained if they are set up as explained on these pages.

The *Acoustic Lens Technology* system ensures better balance in the high tone frequencies coming directly from each loudspeaker, and the sound reflected by the room. The system also ensures correct tonal balance in the whole area in front of the loudspeaker.

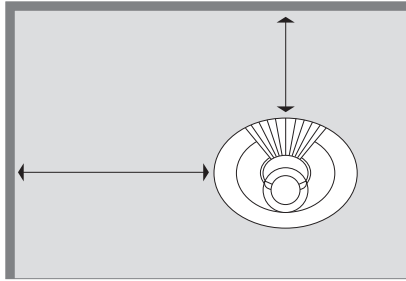

**How to measure?** *The distances referred to are measured as shown here (the loudspeaker seen from above).*

### The FREE-WALL-CORNER switch

When a loudspeaker is placed in a corner or close to a wall, the bass level is boosted compared to the bass level from a loudspeaker placed in a more free-standing position.

To remove this excessive bass boost, set the switch marked FREE-WALL-CORNER to ensure that the bass level suits the placement of the loudspeaker. The appropriate switch setting depends on the distance from the loudspeaker to the walls and corners of the room.

Use the guidelines mentioned here, and the illustration and the examples on the next page, when deciding which of the three POSITION switch setting to select – on each loudspeaker.

### FREE

Use this setting if the loudspeaker is placed more than 20 cm (8") from the wall, and no closer to a corner than 65 cm (26") – shown by the large light grey area in the illustration on the next page.

### WALL

Use this setting if the loudspeaker is placed less than 20 cm (8") from the wall, and no closer to a corner than 65 cm (26") – shown by the grey areas along the walls in the illustration on the next page.

### CORNER

Use this setting if the loudspeaker is placed in a corner – shown by the dark grey areas in the illustration on the next page.

-  FREE
-  WALL
-  CORNER

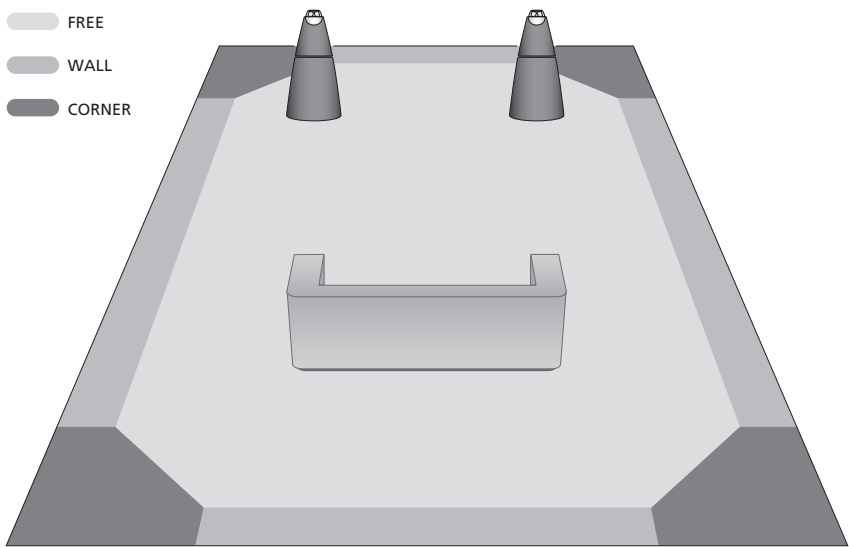

**Position zones:** *The three settings (FREE–WALL–CORNER) corresponds to the position zones marked in different shades of grey shown here. The position zones and the examples shown below, are meant as guidelines – you may, of course, set the switch to any of the three settings you prefer.*

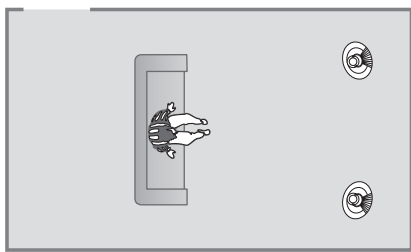

**Example 1:** *The loudspeakers are placed in one end of the room, but not against the back wall, and not near the side walls. Therefore, the switch should be set to FREE on both loudspeakers.*

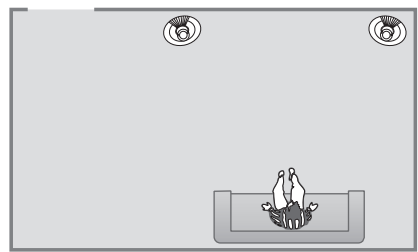

**Example 2:** *One loudspeaker is placed against the wall, and the other is placed in a corner. Therefore, the left loudspeaker should be set to WALL, and the right loudspeaker should be set to CORNER.*

**If you have a BeoLab 2 subwoofer setup ...**

As explained in the BeoLab 2 Guide, the subwoofer has a setup switch which can be set to 1, 2 or 3. The settings of this switch will adapt the output from BeoLab 2 to the sensitivity levels of different loudspeakers.

If you set up a pair of BeoLab 9 loudspeakers in a system with BeoLab 2, we recommend that you set the **BeoLab 2 SETUP** switch to 1.

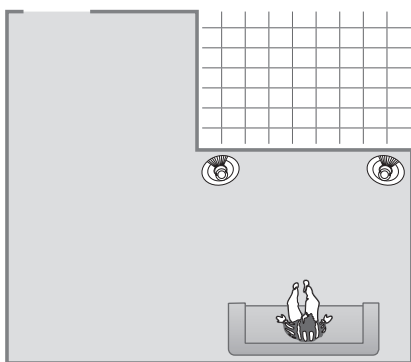

**Example 3:** *As in example 2, one loudspeaker is placed against the wall, and the other is placed in a corner. The shape of the room has no influence on which setting to select. Therefore, the left loudspeaker should be set to WALL, and the right loudspeaker should be set to CORNER.*



### **Waste Electrical and Electronic Equipment (WEEE) – Environmental protection**

The European Parliament and the Council of the European Union have issued the Waste Electrical and Electronic Equipment Directive. The purpose of the Directive is the prevention of waste of electrical and electronic equipment, and to promote the reuse and recycling and other forms of recovery of such waste. As such the Directive concerns producers, distributors and consumers.

The WEEE directive requires that both manufacturers and end-consumers dispose of electrical and electronic equipment and parts in an environmentally safe manner, and that equipment and waste are reused or recovered for their materials or energy.

Electrical and electronic equipment and parts must not be disposed of with ordinary household refuse; all electrical and electronic equipment and parts must be collected and disposed of separately.

Products and equipment which must be collected for reuse, recycling and other forms of recovery are marked with the pictogram shown.

When disposing of electrical and electronic equipment by use of the collection systems available in your country, you protect the environment, human health and contribute to the prudent and rational use of natural resources. Collecting electrical and electronic equipment and waste prevents the potential contamination of nature with the hazardous substances which may be present in electrical and electronic products and equipment. Your Bang & Olufsen retailer will assist with and advise you of the correct way of disposal in your country.

Technical specifications, features and the use thereof are subject to change without notice.

***For the US-market only!***

NOTE: This equipment has been tested and found to comply with the limits for a class B digital device, pursuant to part 15 of the FCC Rules. These limits are designed to provide reasonable protection against harmful interference in a residential installation.

This equipment generates, uses and can radiate radio frequency energy and, if not installed and used in accordance with the instructions, may cause harmful interference to radio communications. However, there is no guarantee that interference will not occur in a particular installation. If this equipment does cause harmful interference to radio or television reception, which can be determined by turning the equipment off and on, the user is encouraged to try to correct the interference by one or more of the following measures:

- Reorient or relocate the receiving antenna.
- Increase the separation between the equipment and receiver.
- Connect the equipment into an outlet on a circuit different from that to which the receiver is connected.
- Consult the retailer or an experienced radio/TV technician for help.

***For the Canadian market only!***

This class B digital apparatus meets all requirements of the Canadian Interference-Causing Equipment Regulations.



*This product fulfils the conditions stated in the EEU directives 89/336 and 73/23.*

